

OWNER'S MANUAL

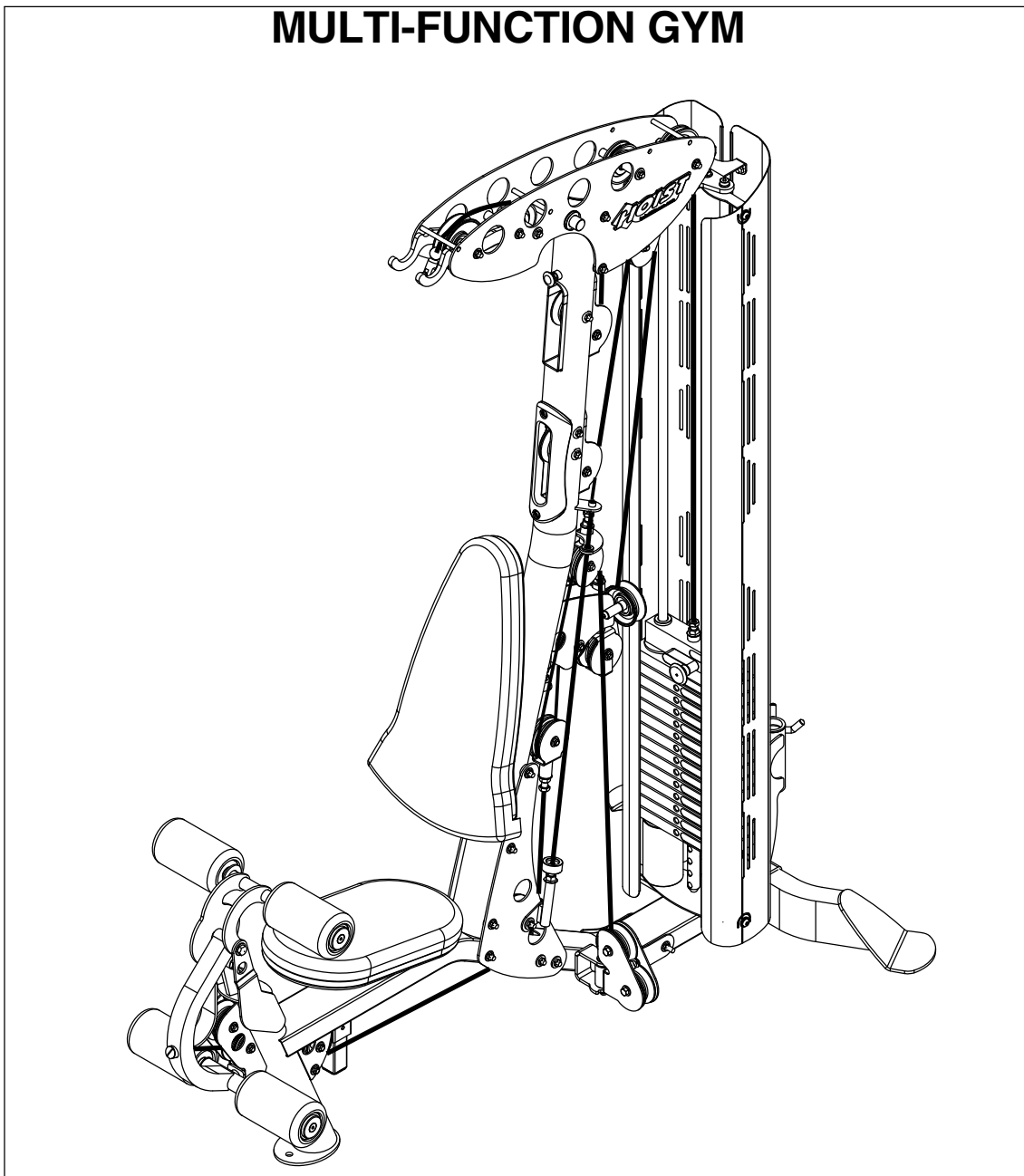

V-SELECT MULTI-FUNCTION GYM



Note: Both Serial Number and Model Number are Required when Ordering Parts

RECORD SERIAL NUMBER HERE

MACHINE CODE

Customer Service

(800) 548-5438

(858) 578-7676

Fax

(858) 578-9558



www.facebook.com/hoistfitness

OWNER'S MANUAL

CONTENTS

INSTRUCTIONS	02
FRAME ASSEMBLY	04
ACCESSORIES/MISC.....	63
PRE-ASSEMBLY.....	64
DECAL PLACEMENT.....	65
DECAL REFERENCE.....	66
PART LIST.....	69
ABBREVIATIONS.....	74
BOLT SIZING CHART.....	75
WASHER SIZING CHART.....	76
MAINTENANCE SCHEDULE.....	78
GENERAL MAINTENANCE INFORMATION.....	79
WEIGHT TRAINING TIPS.....	80
WEIGHT RATIOS.....	81
EXERCISE LOG.....	82
LIMITED WARRANTY.....	83

OWNER'S MANUAL

INSTRUCTIONS

Before beginning assembly please take the time to read instructions thoroughly. Please use the various lists in this manual to make sure that all parts have been included in your shipment. When ordering, use part number and description from the lists. Use only HOIST replacement parts when servicing. Failure to do so will void your warranty and could result in personal injury.

HOIST equipment is designed to provide the smoothest, most effective exercise motion possible. After assembly, you should check all functions to ensure correct operation. If you experience problems, first recheck the assembly instructions to locate any possible errors made during assembly. If you are unable to correct the problem, call your authorized HOIST dealer. Be sure to have your serial number and this manual when calling. When all parts have been accounted for, continue on.

TOOLS REQUIRED

Ratchet Wrench

1/2", 9/16" and 3/4" Sockets

Adjustable Wrench

Rubber Mallet

Tape Measure

Level

Hex Key Wrench Set

Two People

OWNER'S MANUAL

THIS PAGE WAS INTENTIONALLY LEFT BLANK

OWNER'S MANUAL

FRAME ASSEMBLY

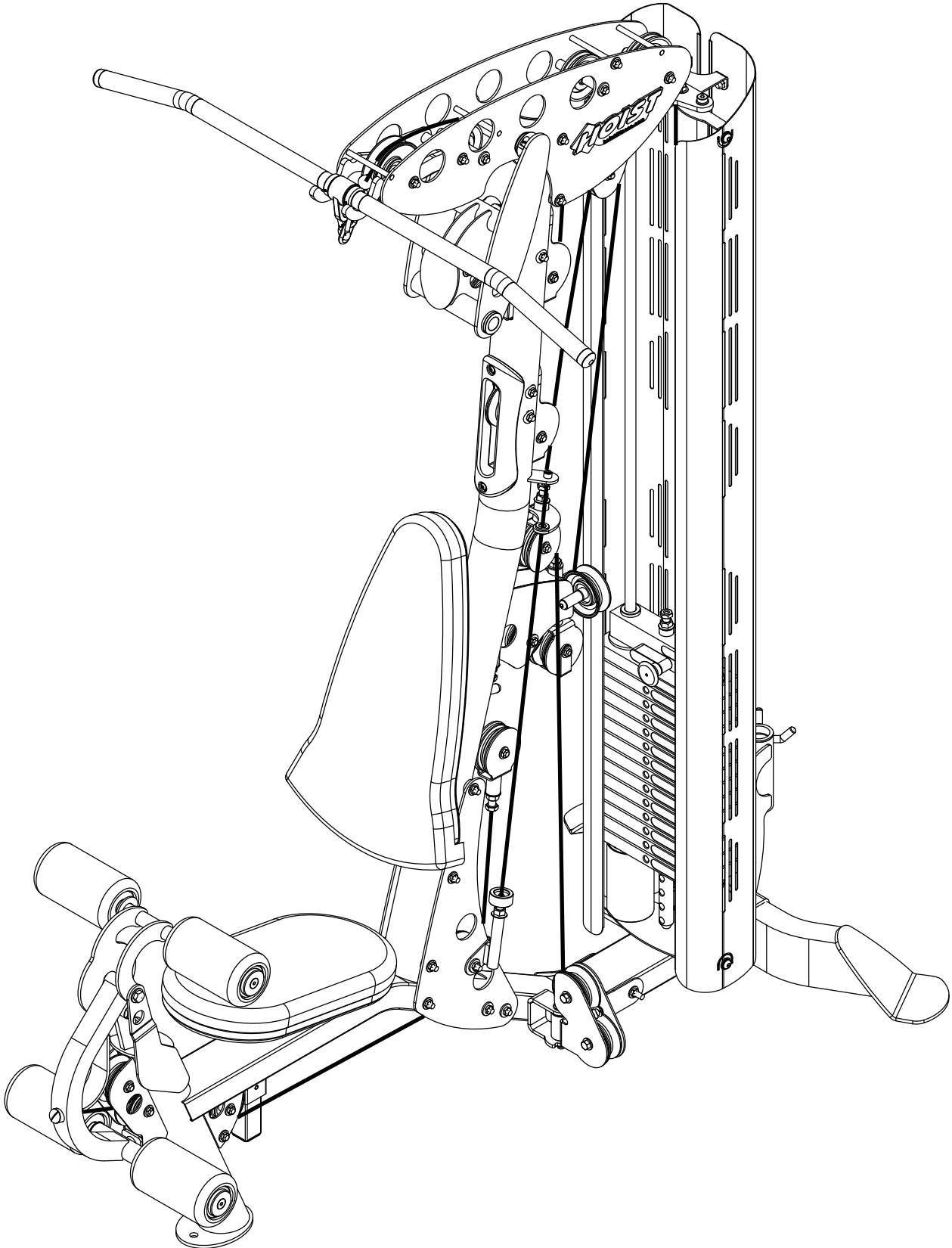

OWNER'S MANUAL

FRAME ASSEMBLY

NOTE:
- HAND TIGHTEN HARDWARE.

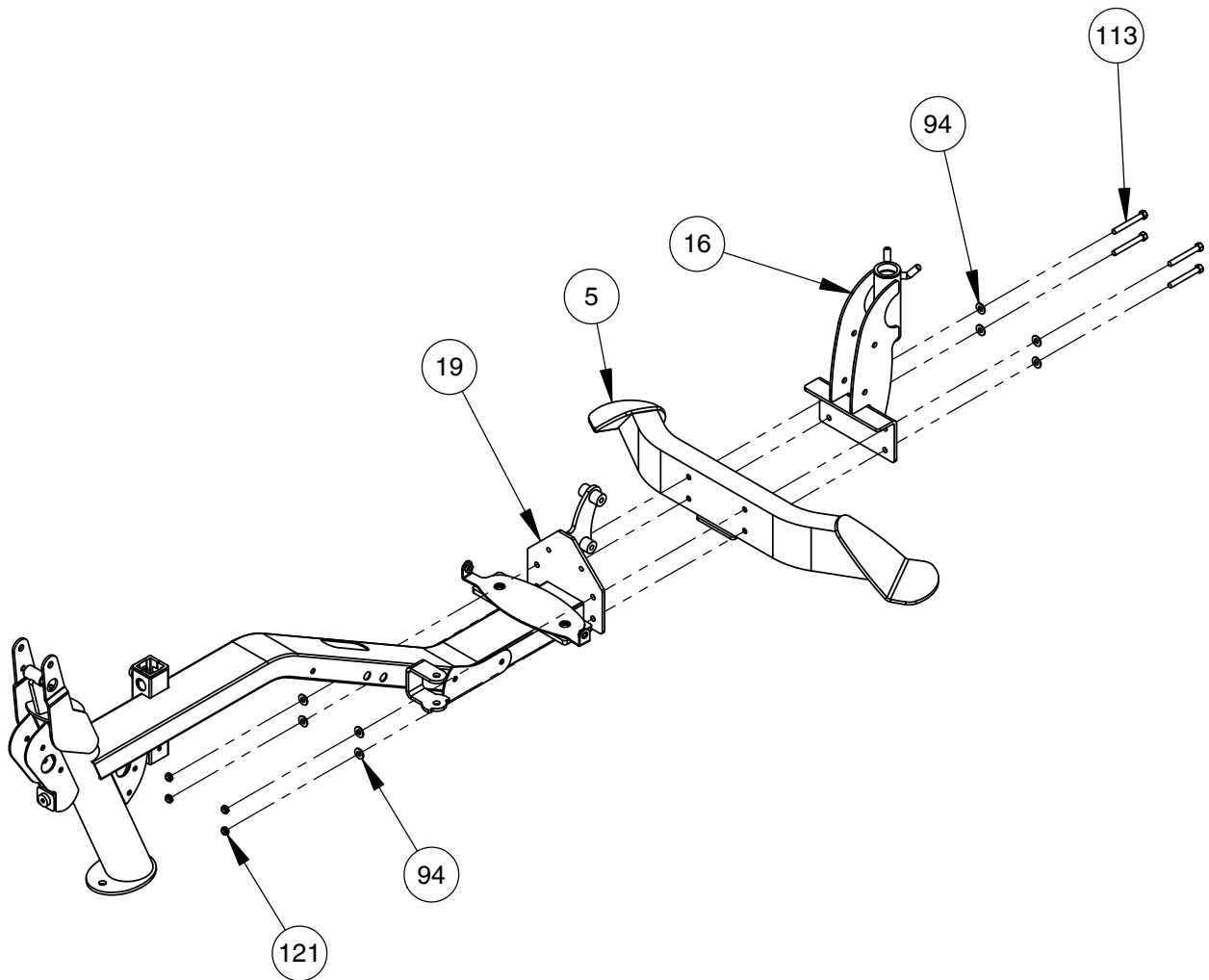

OWNER'S MANUAL

FRAME ASSEMBLY

NOTE:
- HAND TIGHTEN HARDWARE.

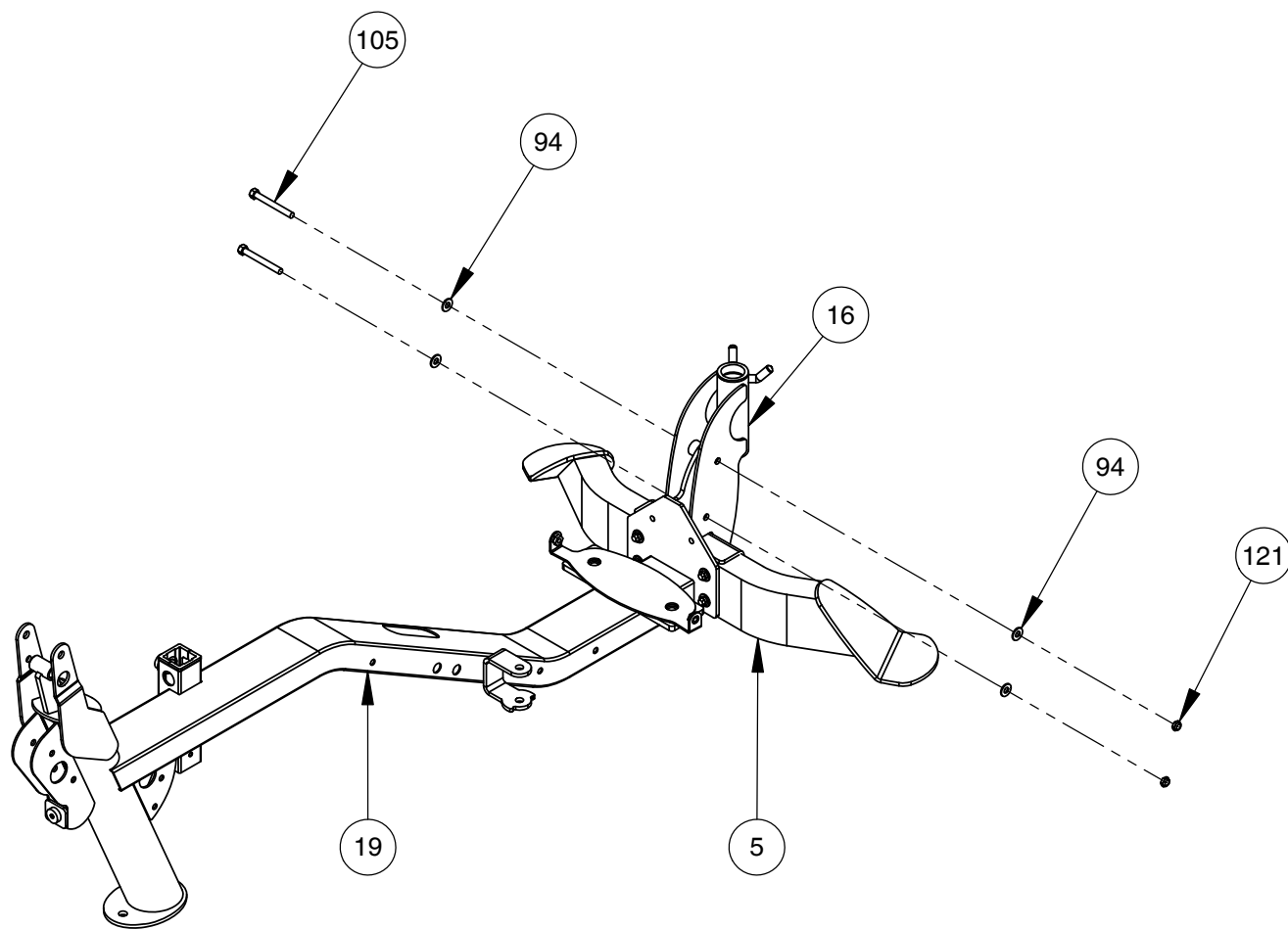

OWNER'S MANUAL

FRAME ASSEMBLY

NOTE:
- WRENCH TIGHTEN HARDWARE.

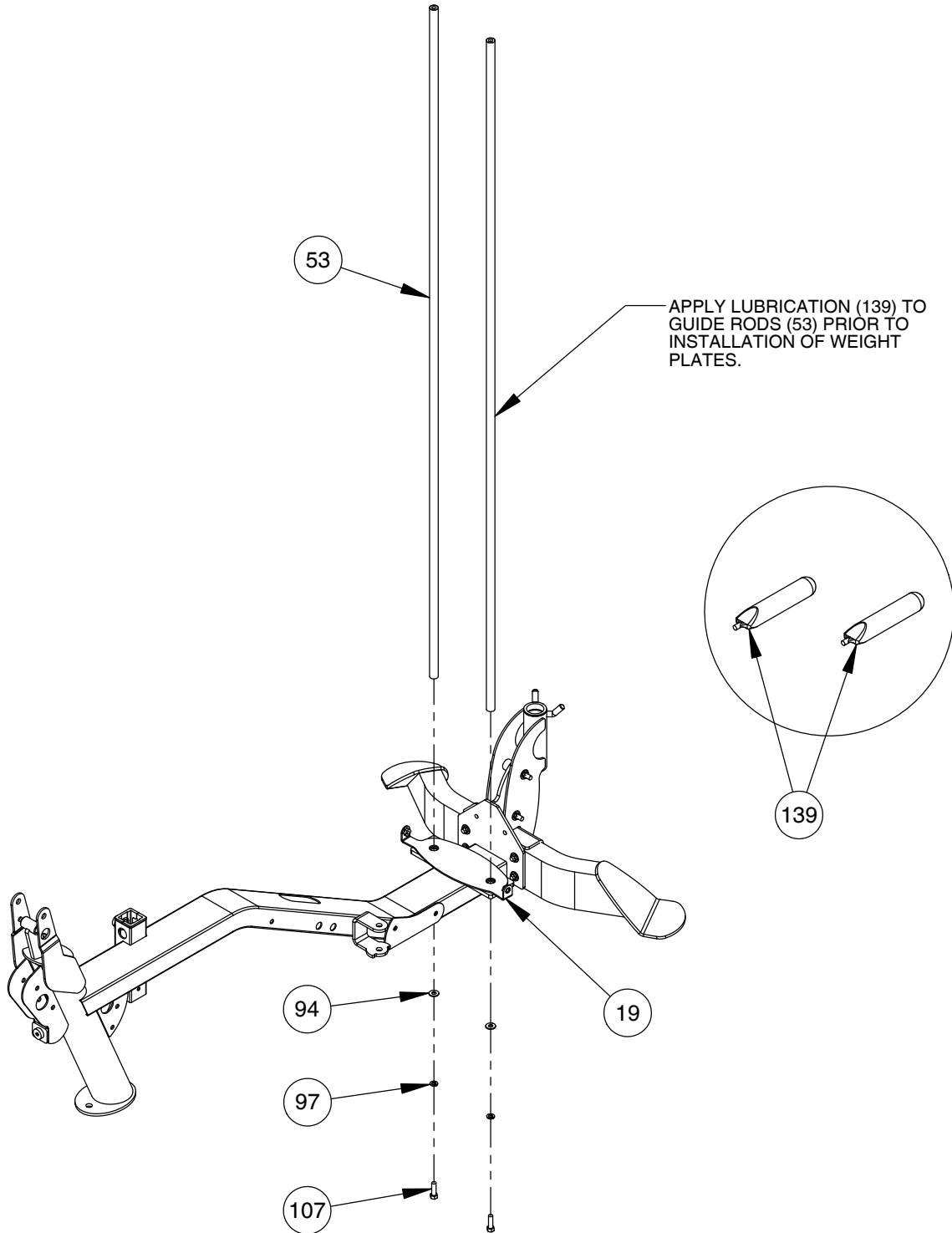

OWNER'S MANUAL

FRAME ASSEMBLY

NOTE:
- SOME PARTS MAY HAVE BEEN REMOVED FOR CLARITY.

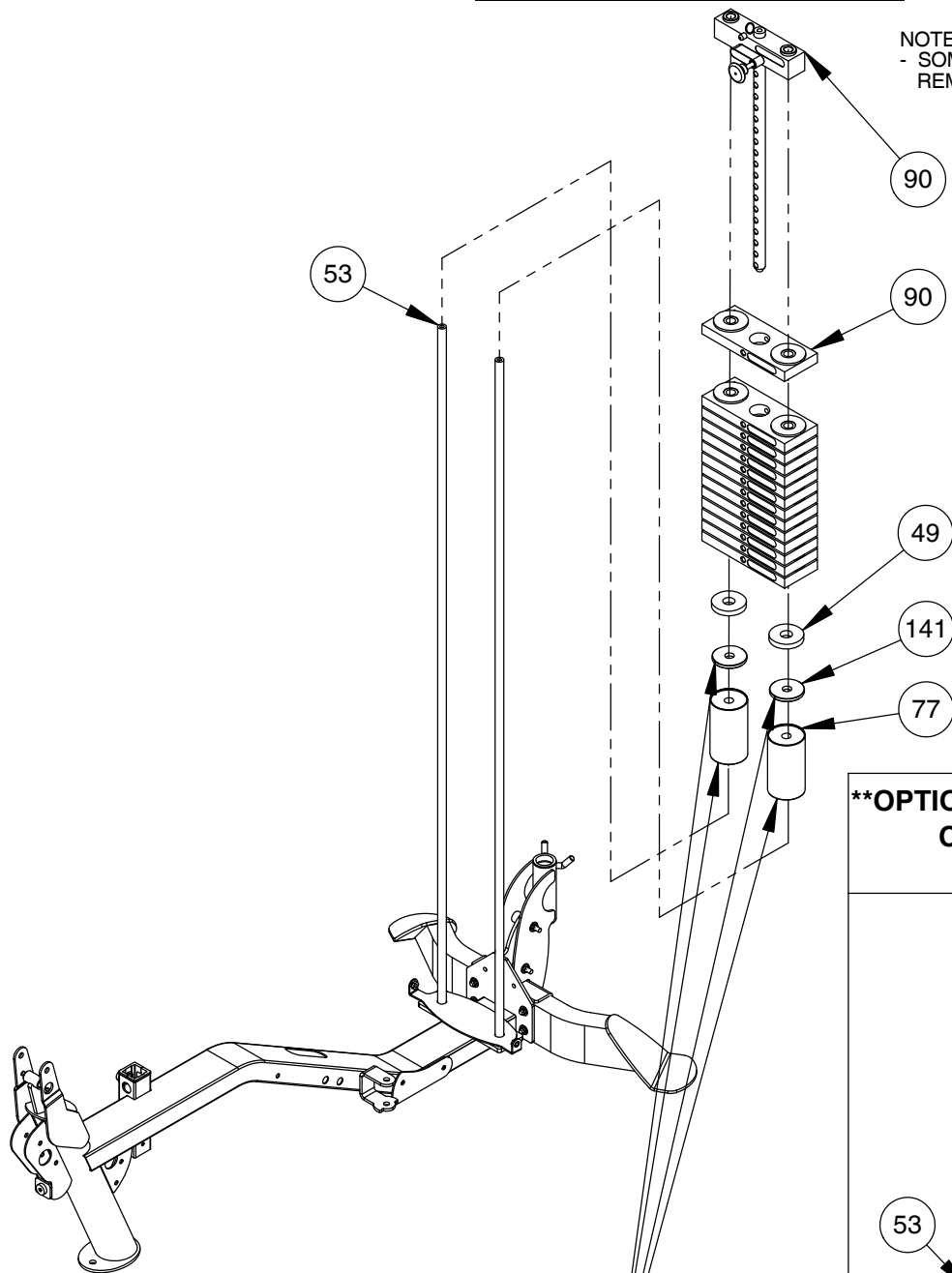

****OPTIONAL 200 LB. WEIGHT STACK****
CONSULT YOUR DEALER
FOR DETAILS

IF OPTIONAL 200 LB. WEIGHT STACK IS PURCHASED, REMOVE AND DISCARD STAND-OFFS (77) AND SPACERS (141) AND ASSEMBLE WEIGHT STACK WITH 5 MORE WEIGHT PLATES, AS SHOWN TO THE RIGHT.

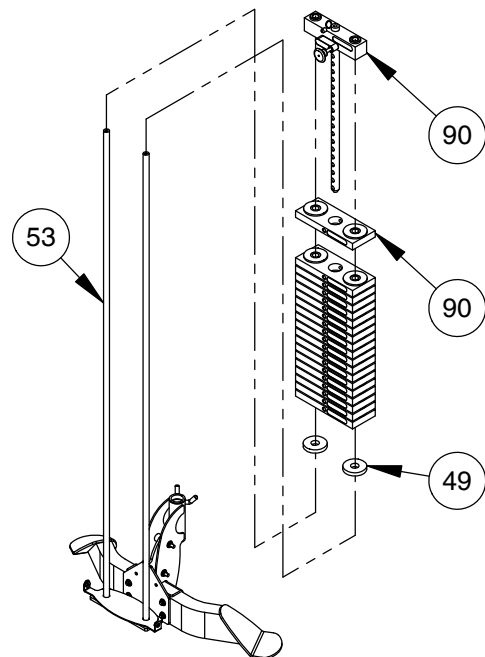

OWNER'S MANUAL

FRAME ASSEMBLY

NOTE:
- HAND TIGHTEN HARDWARE.

WARNING!

BE SURE TO HAVE ONE PERSON FULLY SUPPORT UPRIGHT (11) WHILE THE OTHER ALIGNS AND FASTENS HARDWARE. FAILURE TO FOLLOW THESE INSTRUCTIONS MAY RESULT IN SERIOUS INJURY OR DEATH.

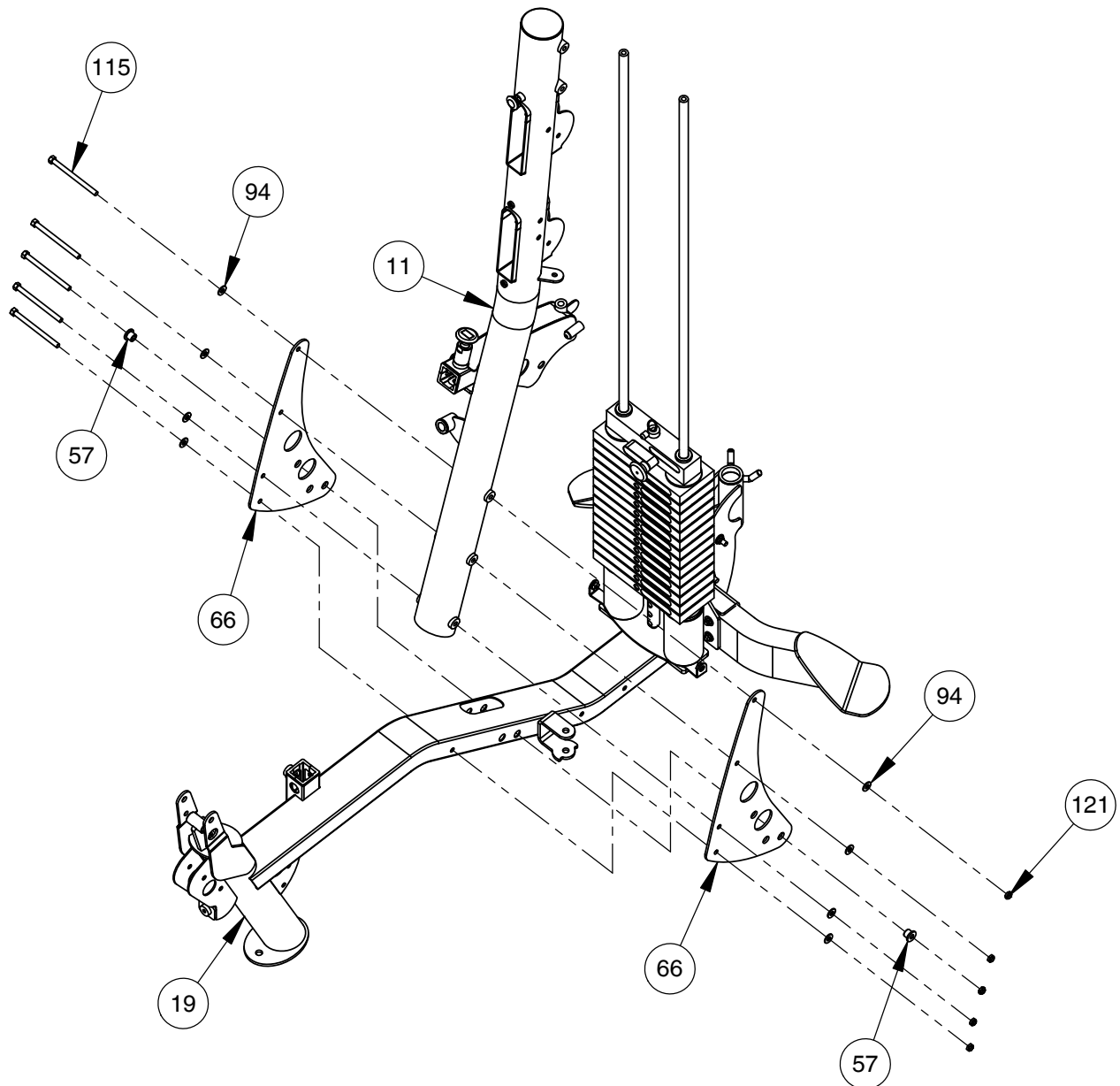

OWNER'S MANUAL

FRAME ASSEMBLY

NOTE:
- HAND TIGHTEN HARDWARE.
- SOME PARTS MAY HAVE BEEN
REMOVED FOR CLARITY.

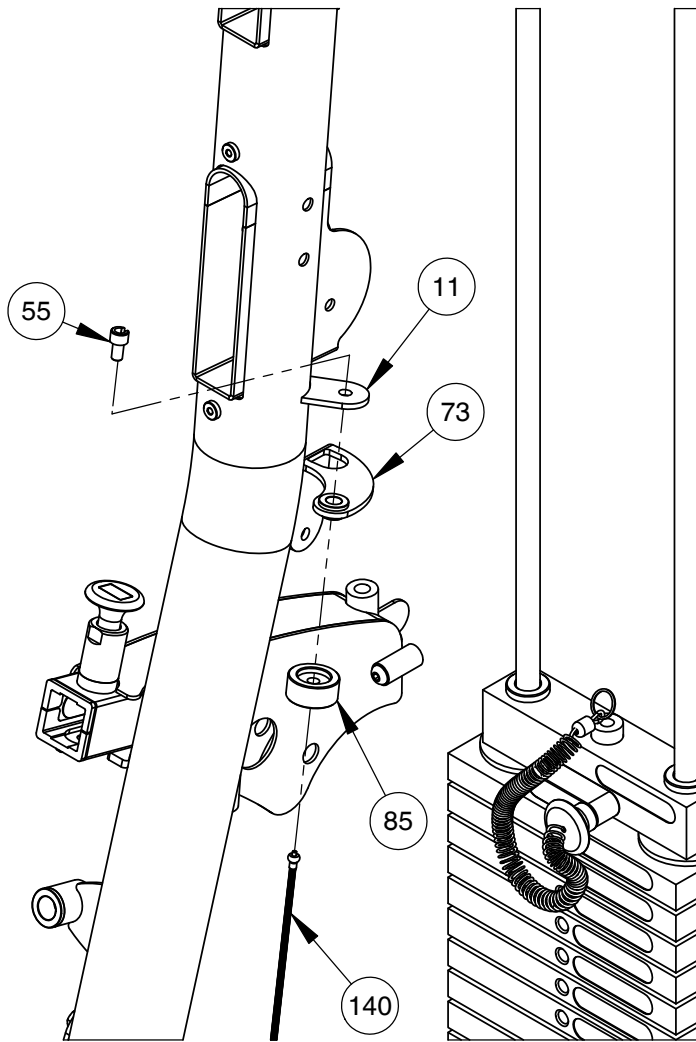

PROPERLY INSTALLED VIEW

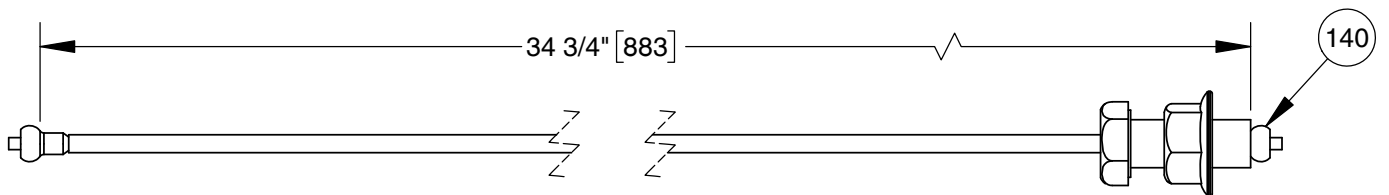
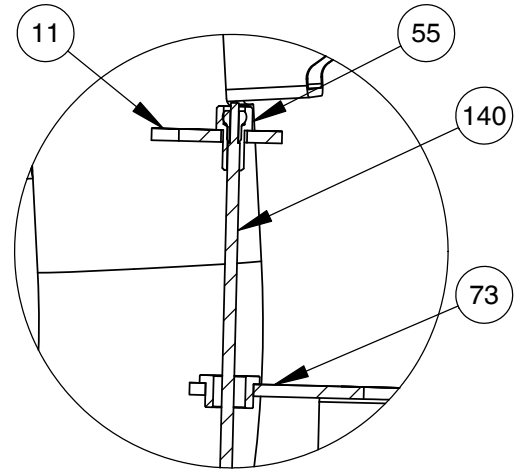

OWNER'S MANUAL

FRAME ASSEMBLY

NOTE:
- HAND TIGHTEN HARDWARE.

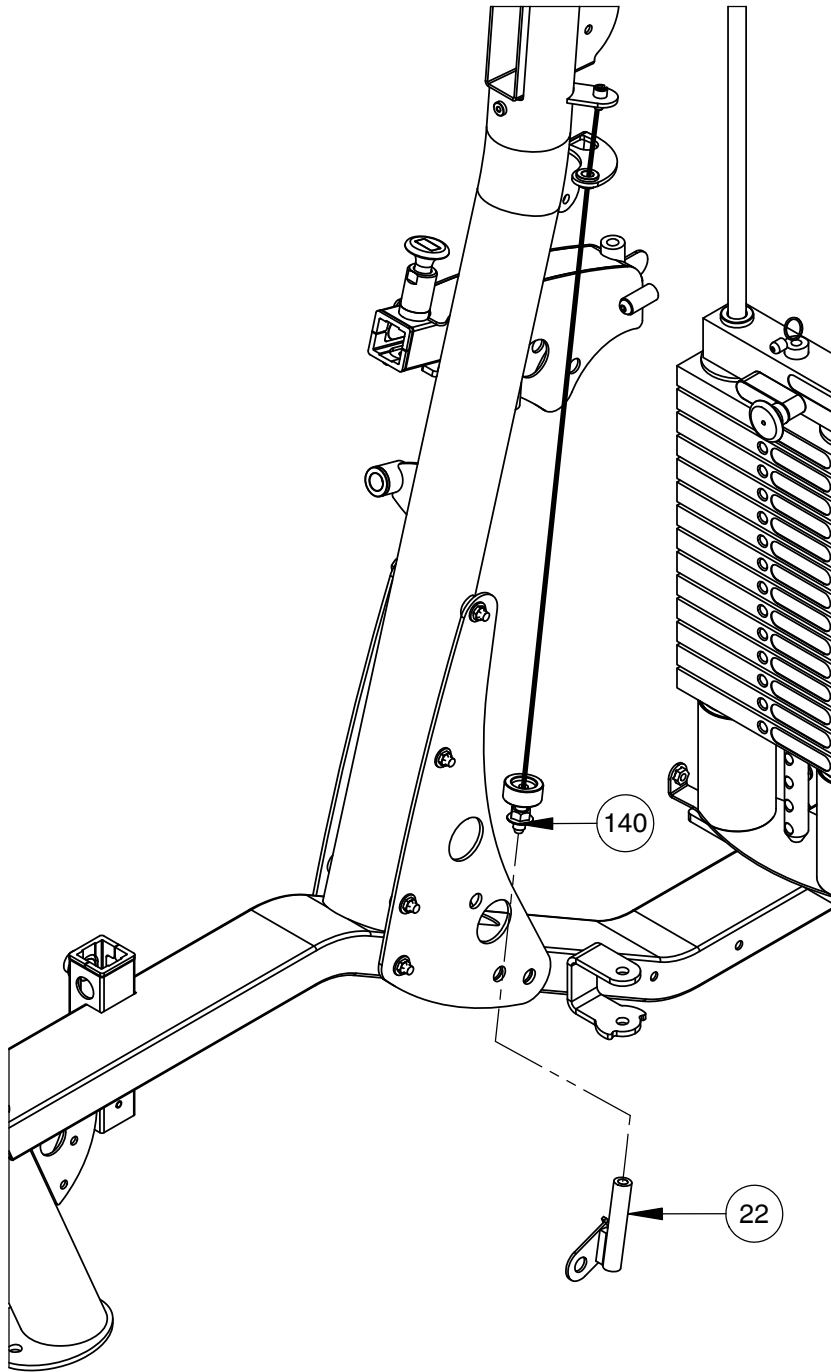

OWNER'S MANUAL

THIS PAGE WAS INTENTIONALLY LEFT BLANK

OWNER'S MANUAL

FRAME ASSEMBLY

NOTE:
- HAND TIGHTEN HARDWARE.

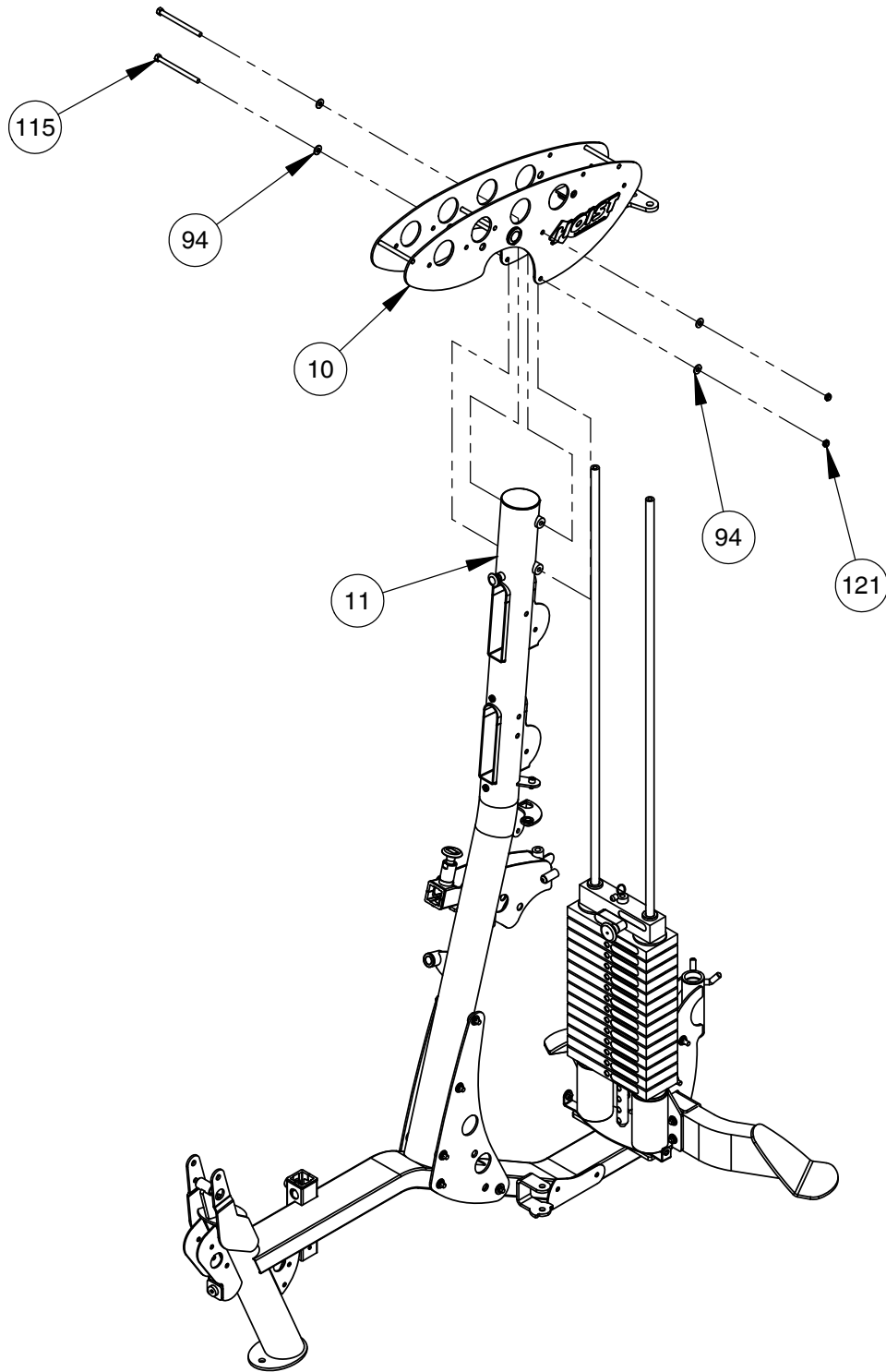

OWNER'S MANUAL

FRAME ASSEMBLY

NOTE:
- WRENCH TIGHTEN HARDWARE.

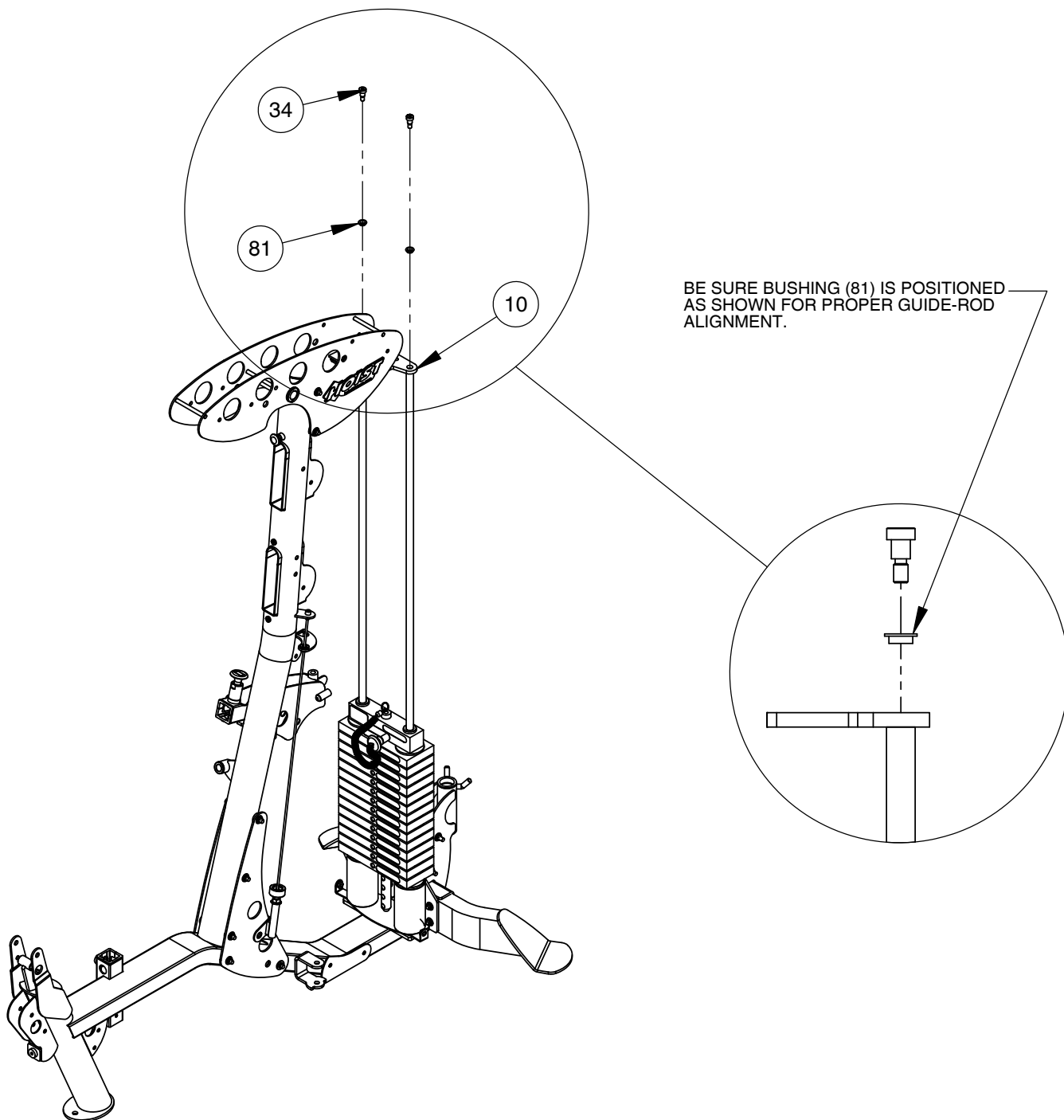

OWNER'S MANUAL

FRAME ASSEMBLY

IMPORTANT

If you are installing a V HI-LO Option refer to the V HI-LO owner's manual and assemble the V HI-LO frame part at this time.

NOTE:
- HAND TIGHTEN HARDWARE.

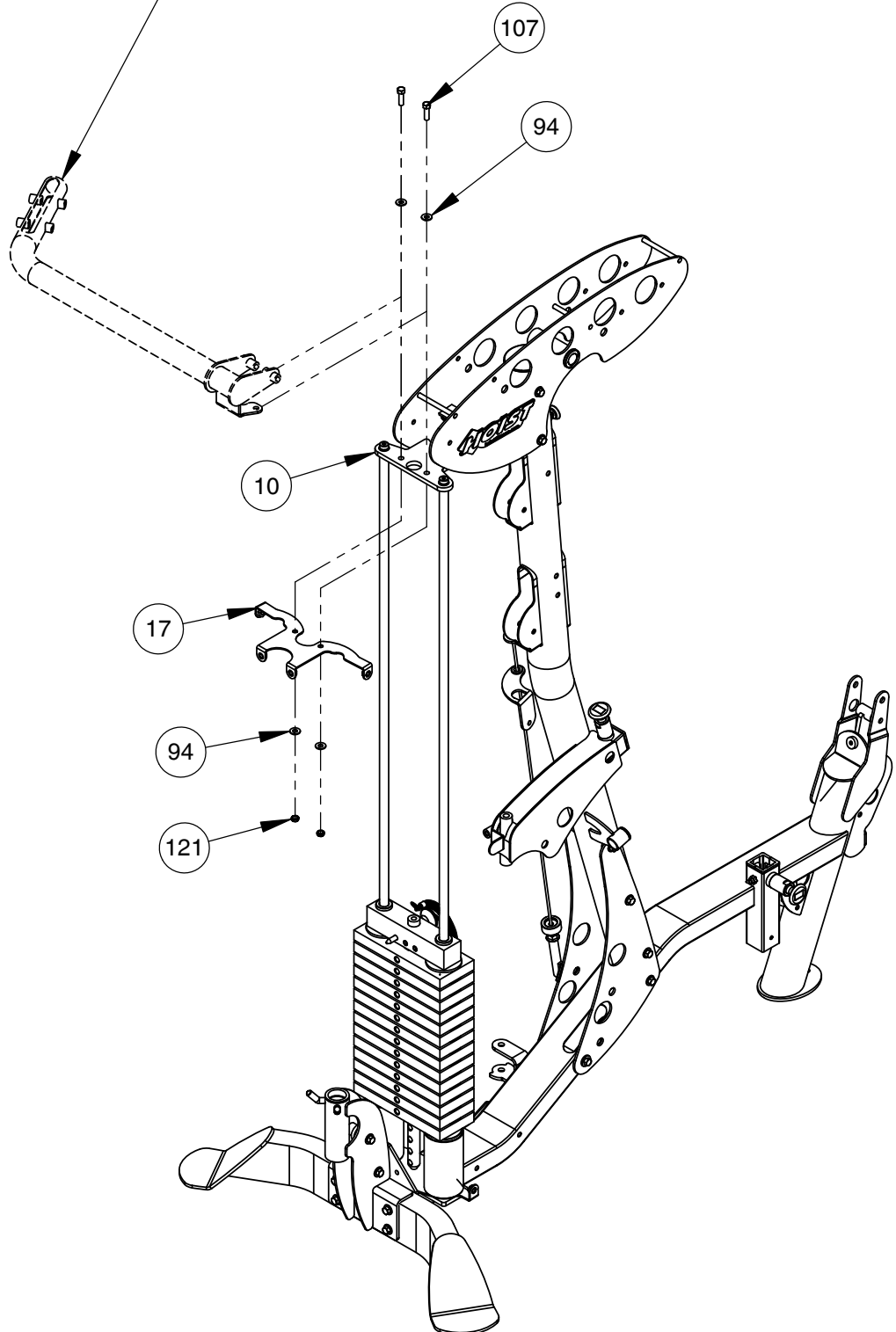

OWNER'S MANUAL

FRAME ASSEMBLY

NOTE:
- HAND TIGHTEN HARDWARE.
* FOR INSTALLATION OF V LEG PRESS OPTION, DISCARD PLATE (69).

IMPORTANT:
If you are installing a V Leg Press Option refer to the V Leg Press owner's manual and assemble the V Leg Press frame parts at this time.

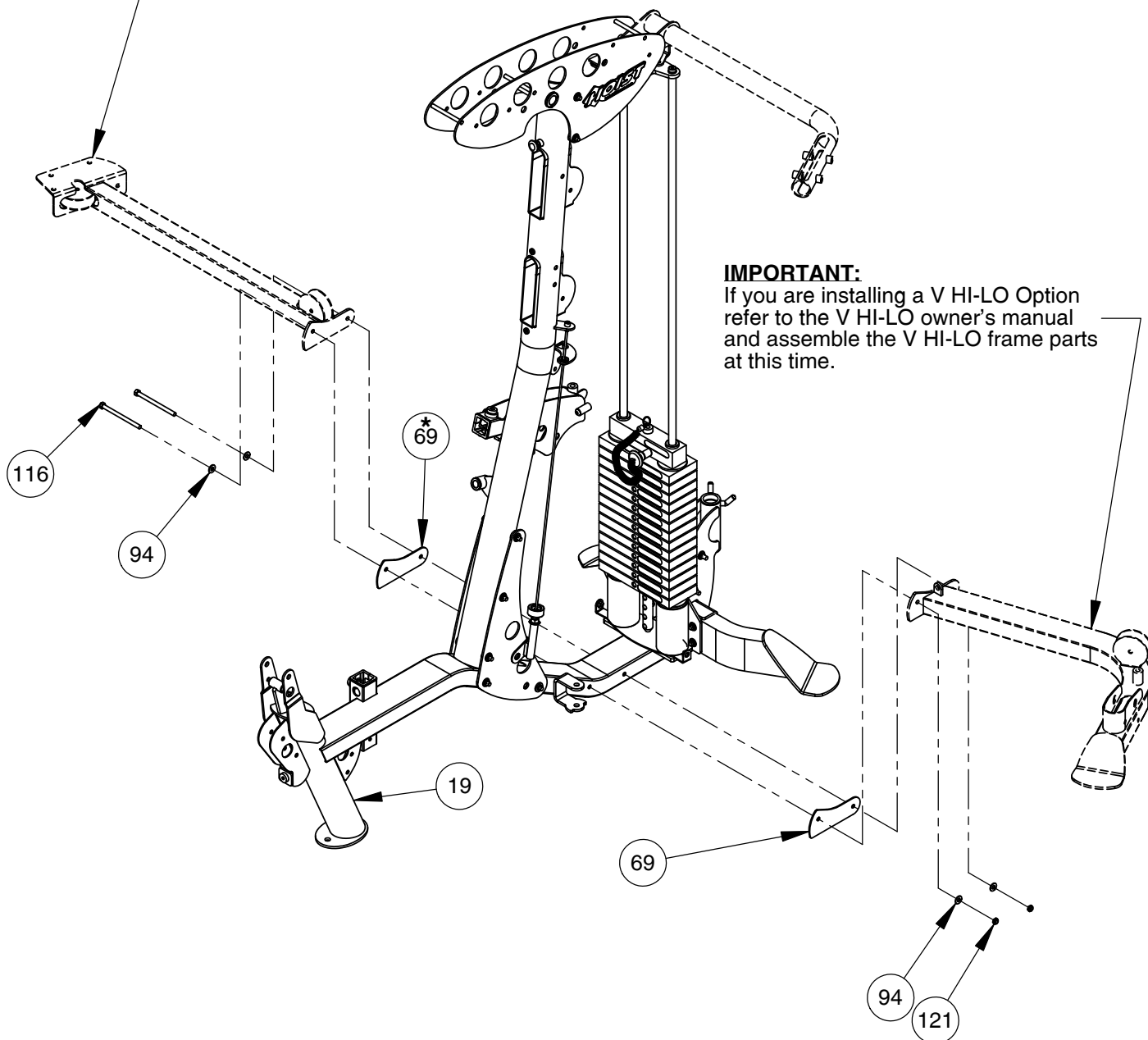

IMPORTANT:
If you are installing a V HI-LO Option refer to the V HI-LO owner's manual and assemble the V HI-LO frame parts at this time.

OWNER'S MANUAL

FRAME ASSEMBLY

NOTE:
- WRENCH TIGHTEN HARDWARE (117)
THEN LOOSEN NUT JUST ENOUGH
FOR (20) TO PIVOT FREELY.

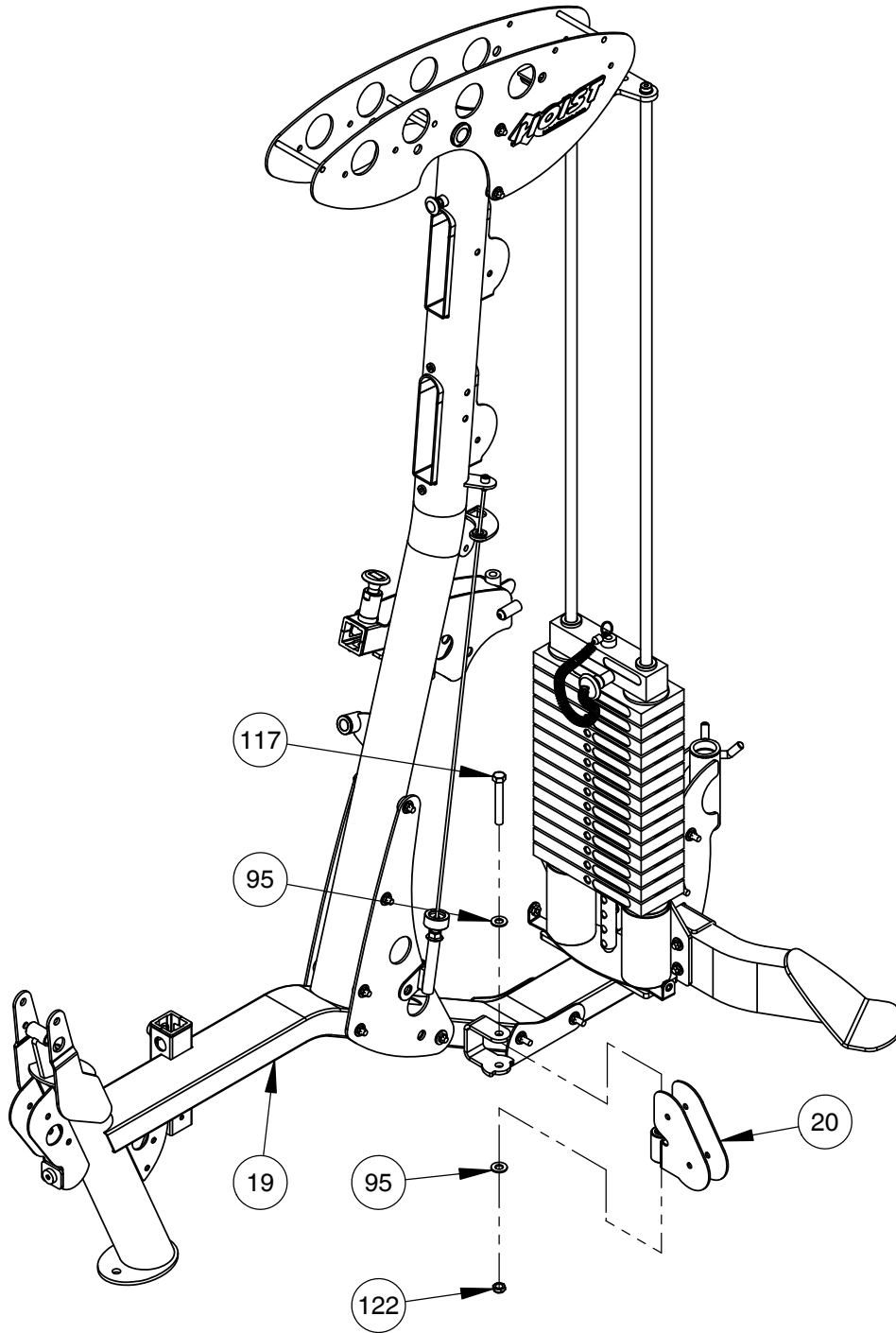

OWNER'S MANUAL

FRAME ASSEMBLY

NOTE:
- WRENCH TIGHTEN HARDWARE (135)
THEN LOOSEN NUT JUST ENOUGH
FOR (14, 8) TO PIVOT FREELY.

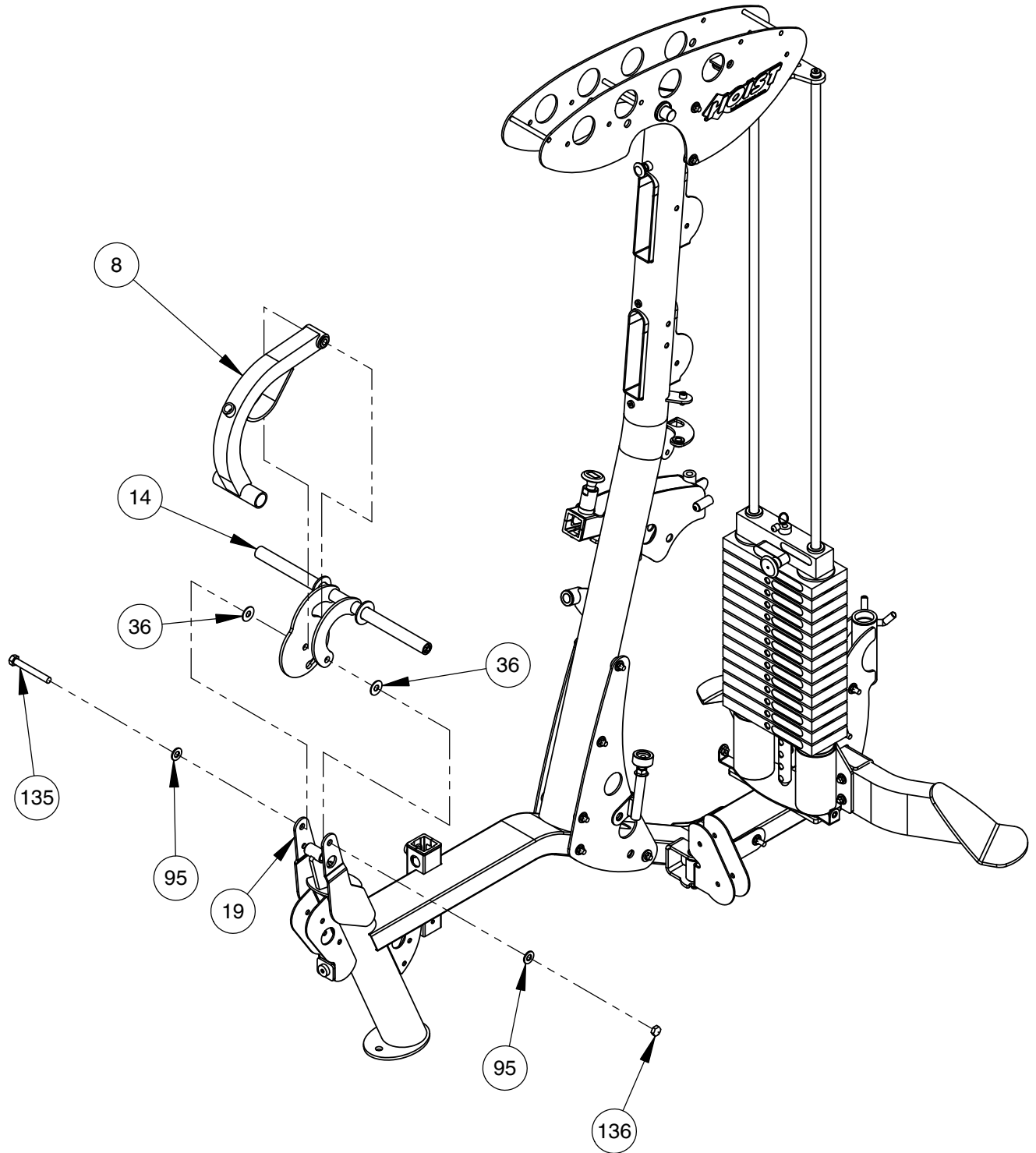

OWNER'S MANUAL

FRAME ASSEMBLY

NOTE:

- WRENCH TIGHTEN HARDWARE.
- WRENCH TIGHTEN ALL HARDWARE FROM PREVIOUS STEPS.

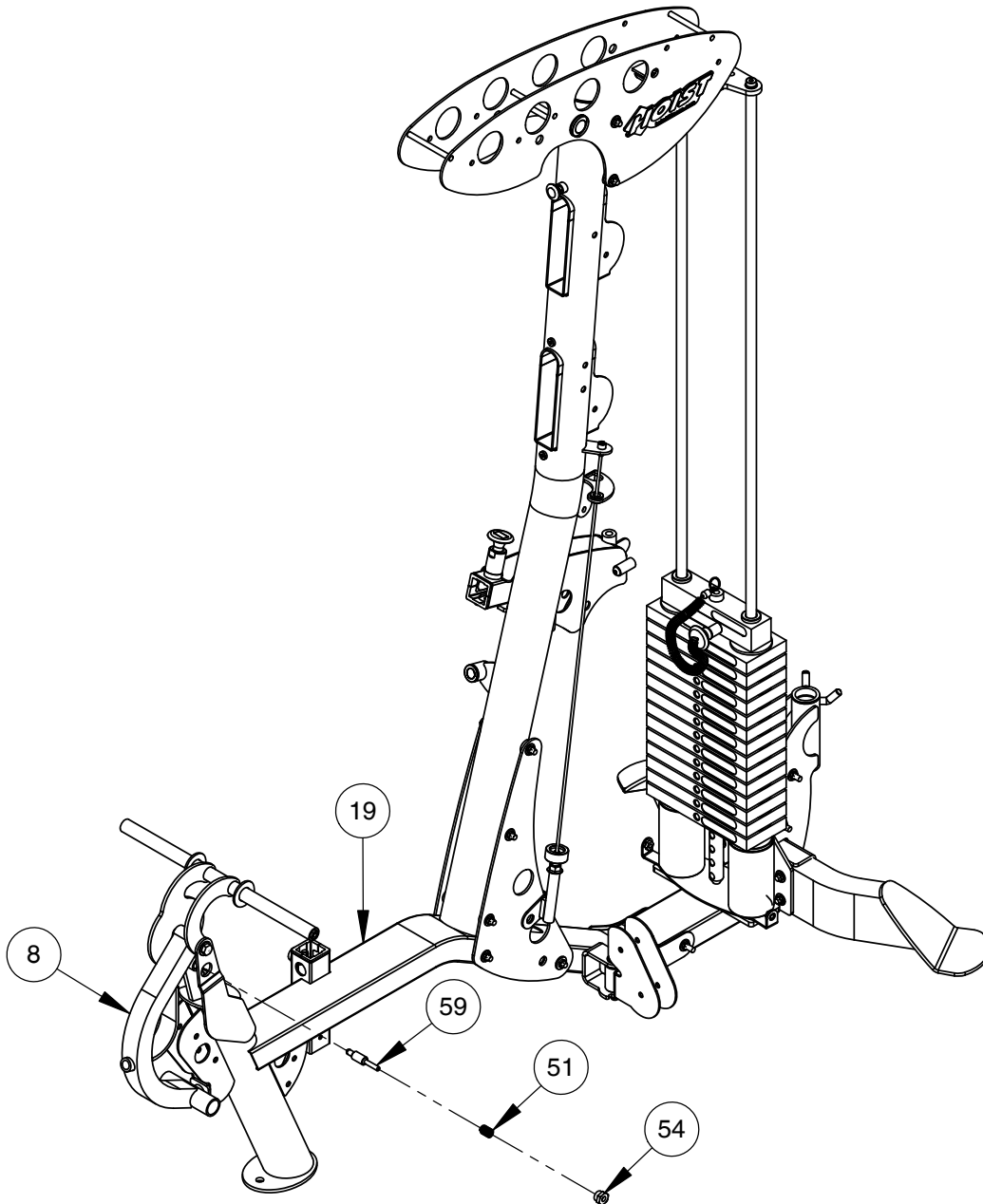

IMPORTANT

NOW THAT THE V-SELECT FRAME IS ASSEMBLED TAKE TIME TO ASSURE THAT YOUR UNIT IS ASSEMBLED SQUARE AND PERPENDICULAR. USE A LEVEL TO CHECK THAT THE GUIDE RODS ARE PERPENDICULAR IN BOTH DIRECTIONS. IF NOT, IT WILL BE NECESSARY TO LOOSEN SOME FRAME HARDWARE TO RE-ALIGN THE FRAME AND RETIGHTEN BOLTS.

OWNER'S MANUAL

FRAME ASSEMBLY

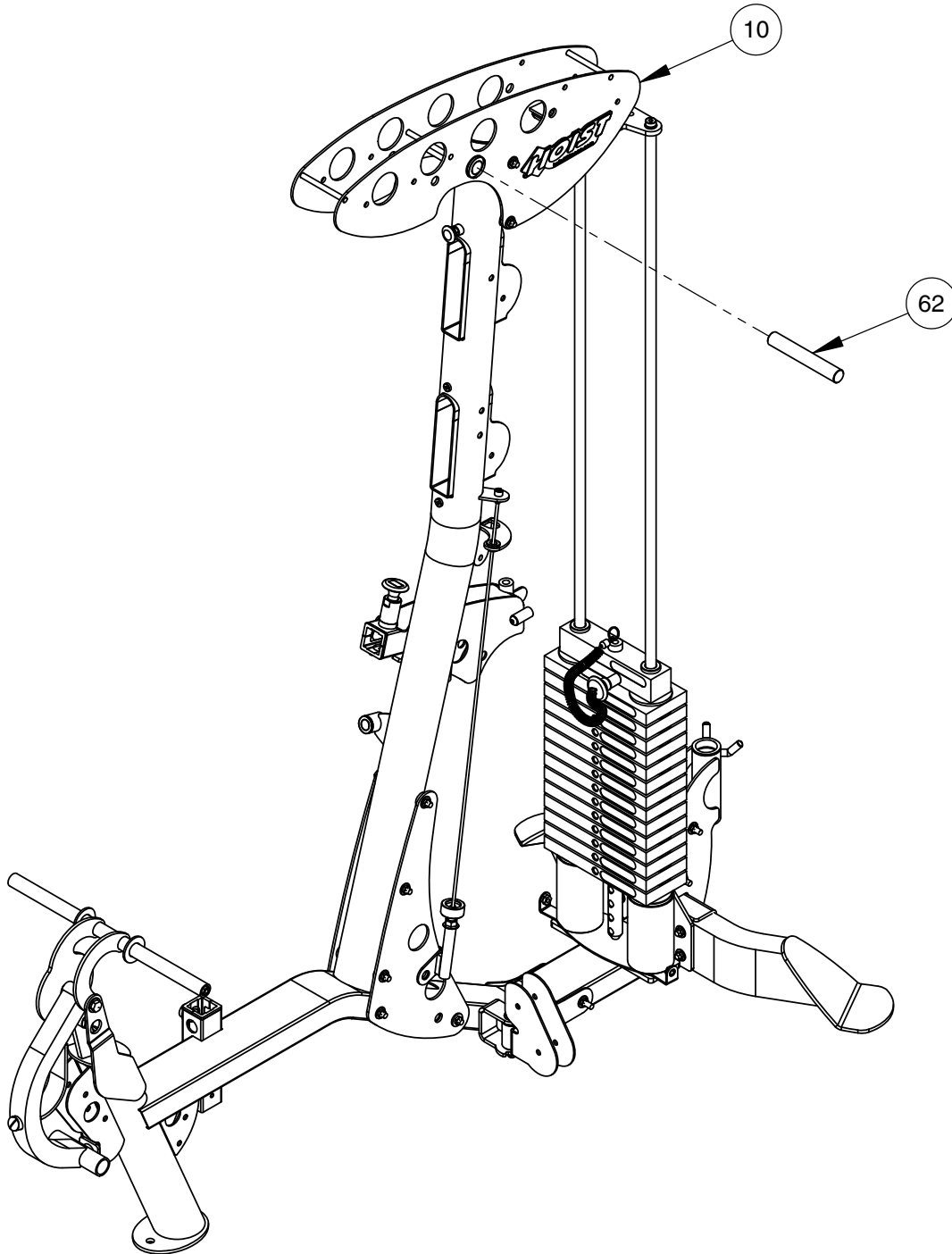

OWNER'S MANUAL

FRAME ASSEMBLY

* 026-01X5083
PRESS ARM HANGER ASSEMBLY

NOTE:
* THIS PART ORIGINALLY INCLUDED
IN V-PRESS ARM UNIT.

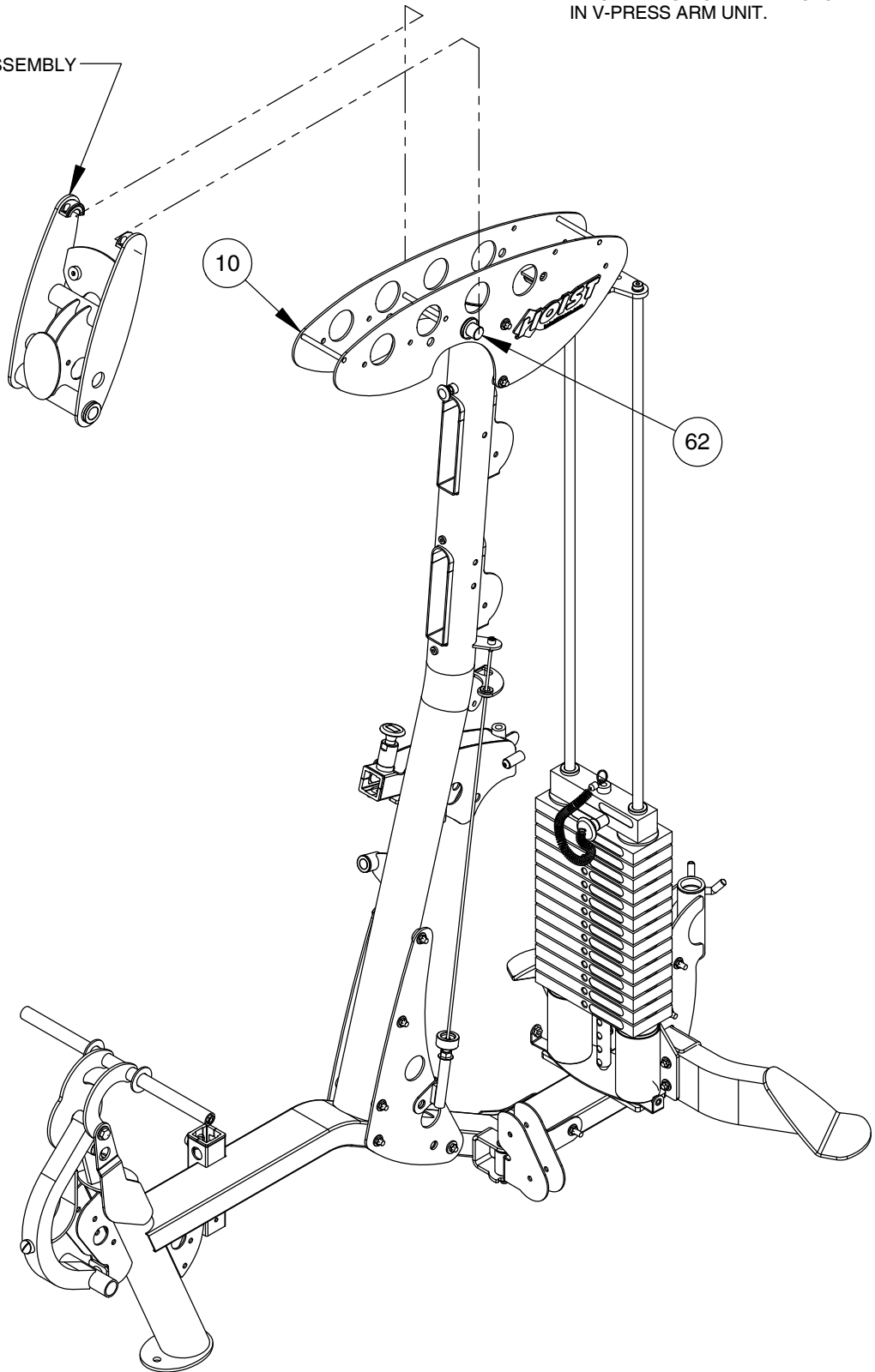

OWNER'S MANUAL

FRAME ASSEMBLY

NOTE:
- WRENCH TIGHTEN HARDWARE.
* THIS PART ORIGINALLY INCLUDED
IN V-PRESS ARM UNIT.

*011-0007097
1/4"-20UNC X .75" SHCS (BZ)

* 026-1X5083
PRESS ARM HANGER ASSEMBLY

* 014-0019005-1
T SPLIT COLLAR THREADED 1.00" I.D. X 20mm

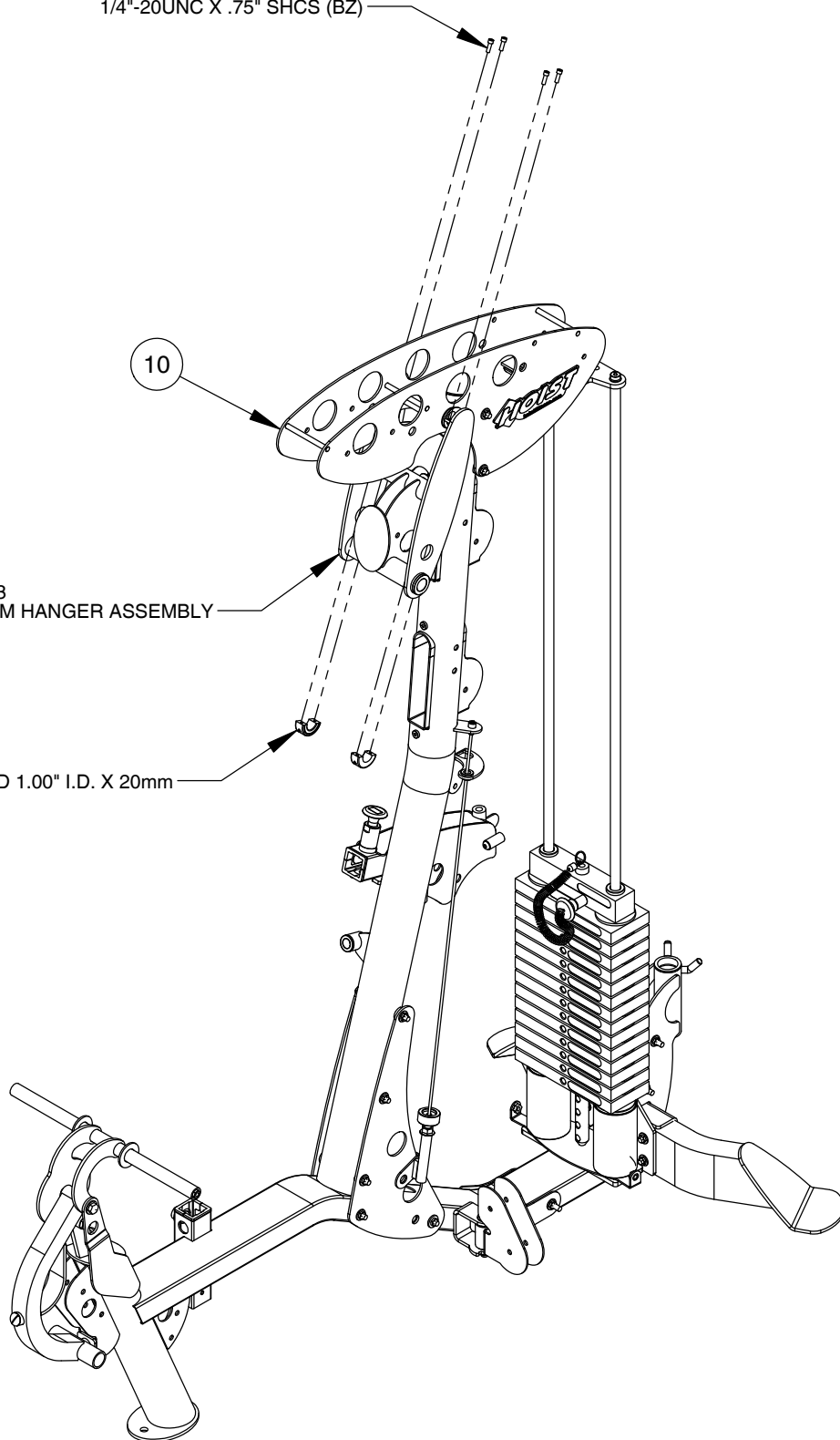

OWNER'S MANUAL

FRAME ASSEMBLY

CABLING PROFILE VIEW

NOTE:
- SOME PARTS MAY HAVE BEEN
REMOVED FOR CLARITY.

NOTE:
BE SURE **CABLE** RUNS
BETWEEN THE PULLEYS AND
GUARD RODS AS SHOWN.

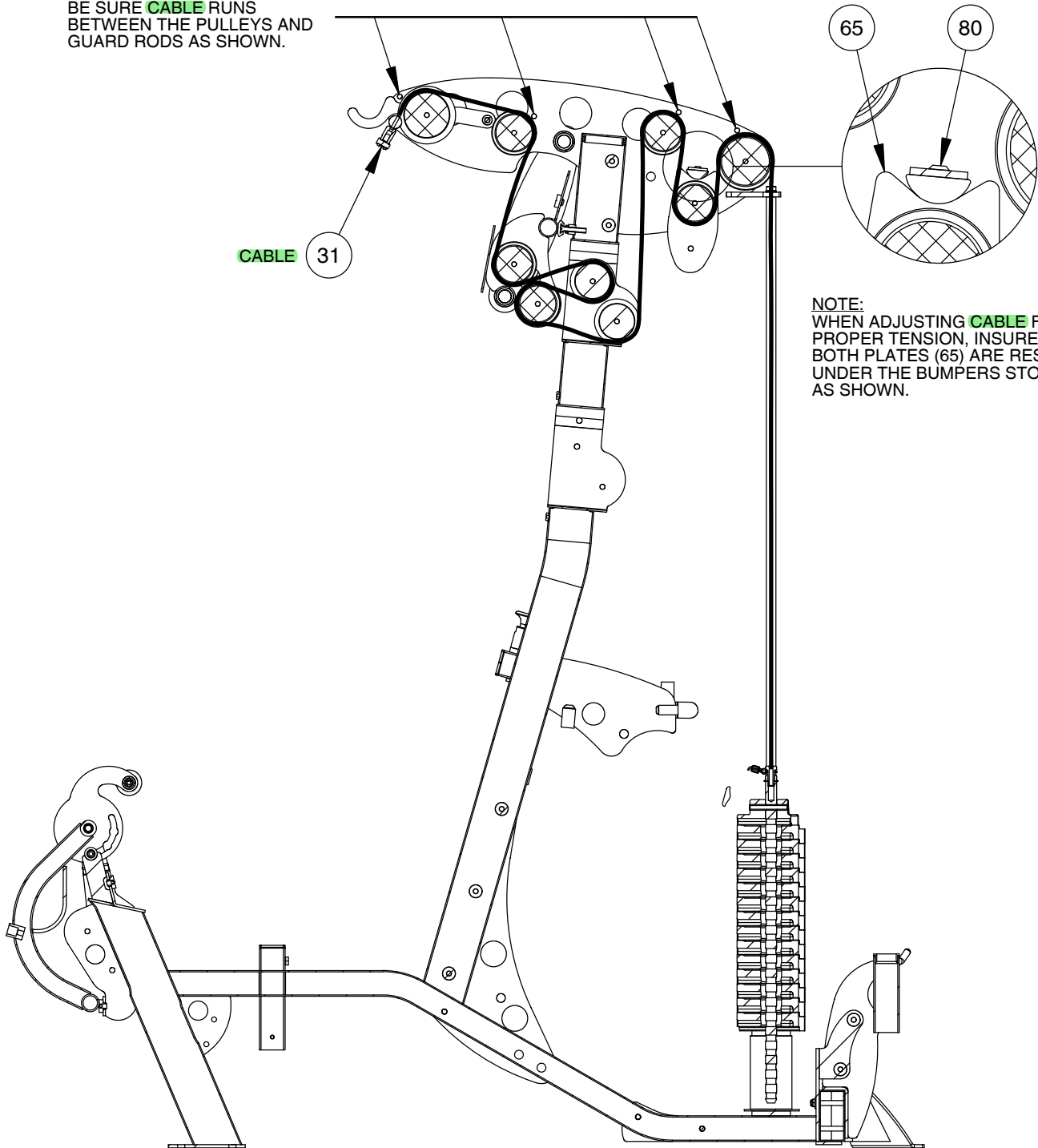

NOTE:
WHEN ADJUSTING **CABLE** FOR
PROPER TENSION, INSURE THAT
BOTH PLATES (65) ARE RESTING
UNDER THE BUMPER STOP (80)
AS SHOWN.

OWNER'S MANUAL

FRAME ASSEMBLY

PROPERLY INSTALLED VIEW

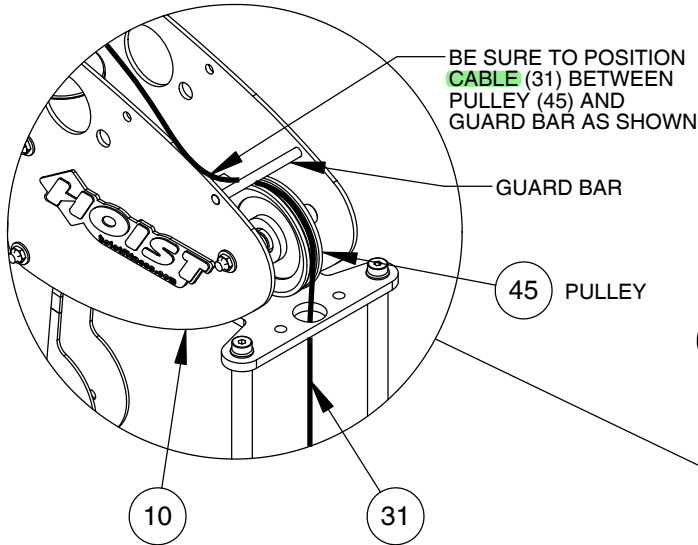

NOTE:

- WRENCH TIGHTEN HARDWARE.
- INSTALL **CABLE** AND PULLEYS AT THE SAME TIME.
- SOME PARTS MAY HAVE BEEN REMOVED FOR CLARITY.

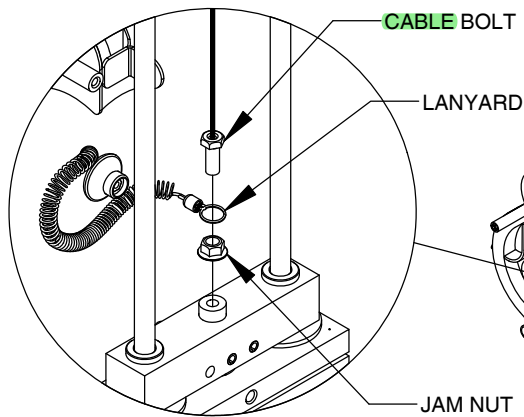

FINE TUNING:

LOOSEN JAM NUT AND THREAD **CABLE BOLT** IN/OUT TO GIVE THE **CABLE** PROPER TENSION. RE-TIGHTEN JAM NUT.

WARNING - CABLE BOLT MUST BE THREADED A MINIMUM OF 3/8" WITH JAM NUT TIGHTENED SECURELY TO ENSURE PROPER CONNECTION.

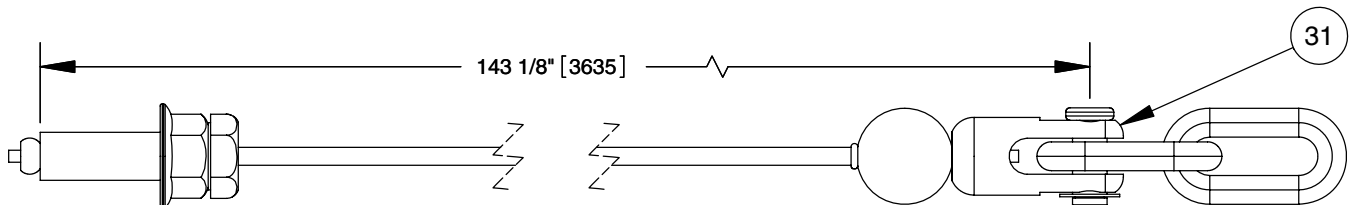
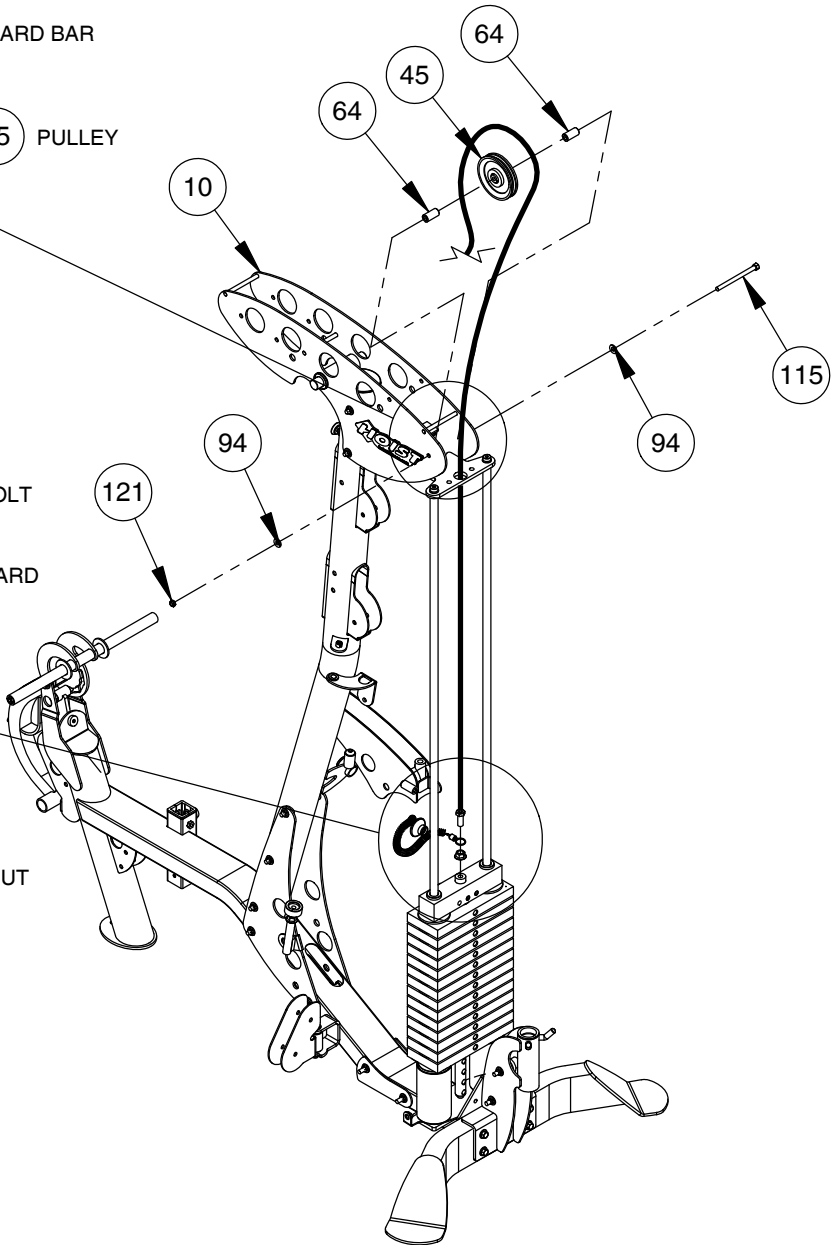

OWNER'S MANUAL

FRAME ASSEMBLY

NOTE:

- HAND TIGHTEN HARDWARE.
- SOME PARTS MAY HAVE BEEN REMOVED FOR CLARITY.
- INSTALL **CABLE** AND PULLEYS AT THE SAME TIME.

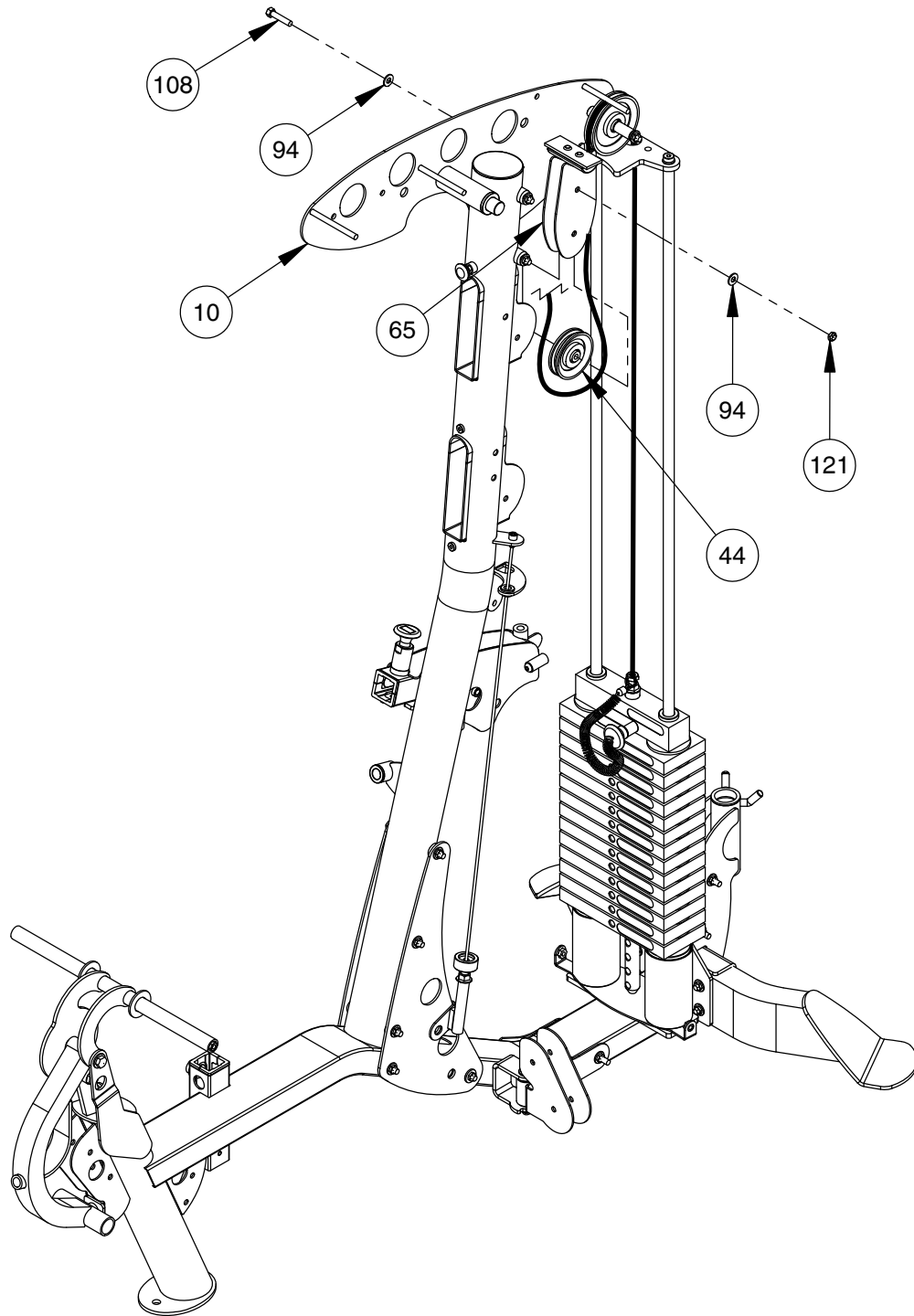

OWNER'S MANUAL

FRAME ASSEMBLY

NOTE:

- WRENCH TIGHTEN HARDWARE.
- SOME PARTS MAY HAVE BEEN REMOVED FOR CLARITY.
- INSTALL **CABLE** AND PULLEYS AT THE SAME TIME.

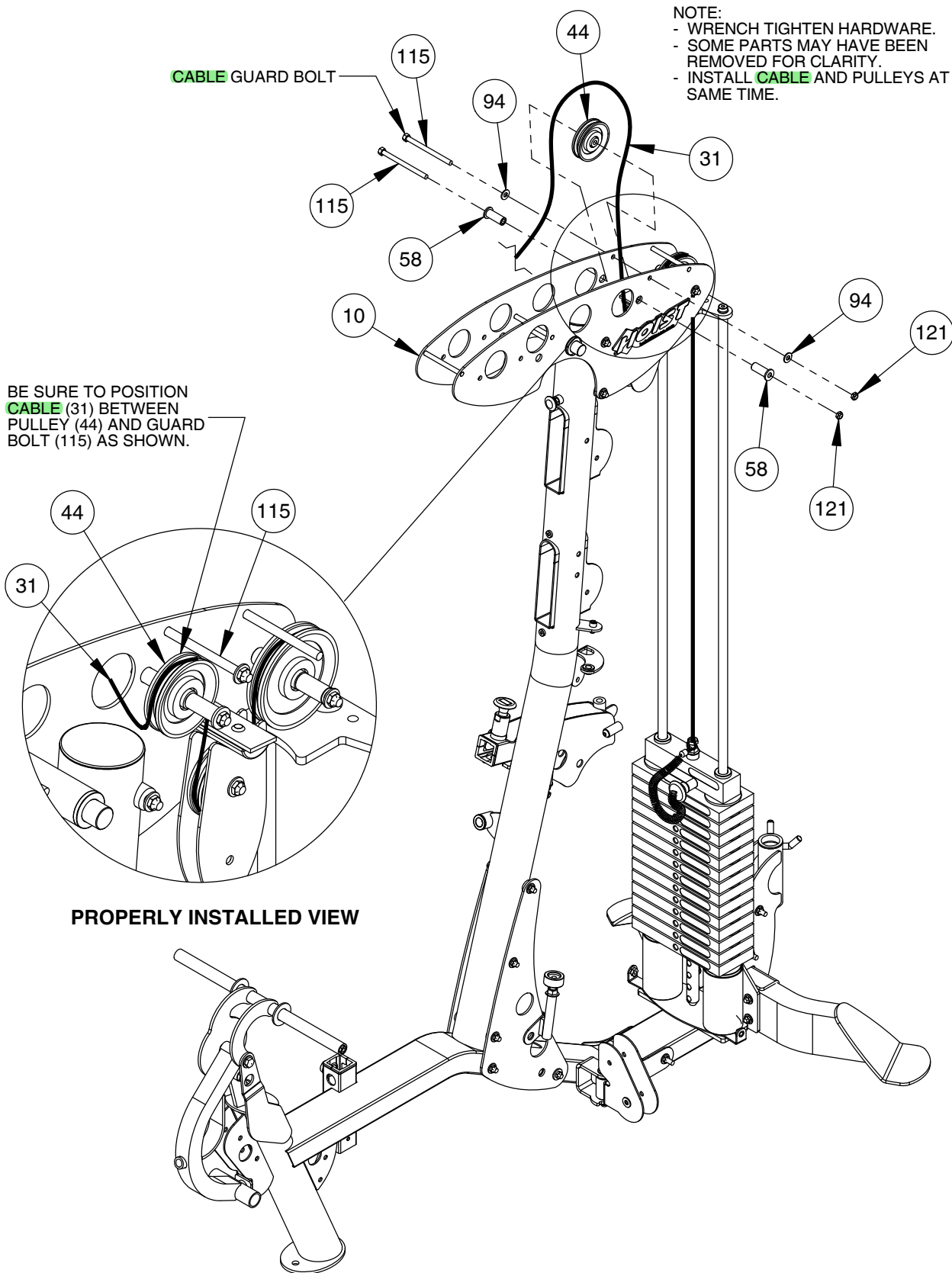

OWNER'S MANUAL

FRAME ASSEMBLY

- NOTE:
- WRENCH TIGHTEN HARDWARE.
 - SOME PARTS MAY HAVE BEEN REMOVED FOR CLARITY.
 - INSTALL **CABLE** AND PULLEYS AT THE SAME TIME.

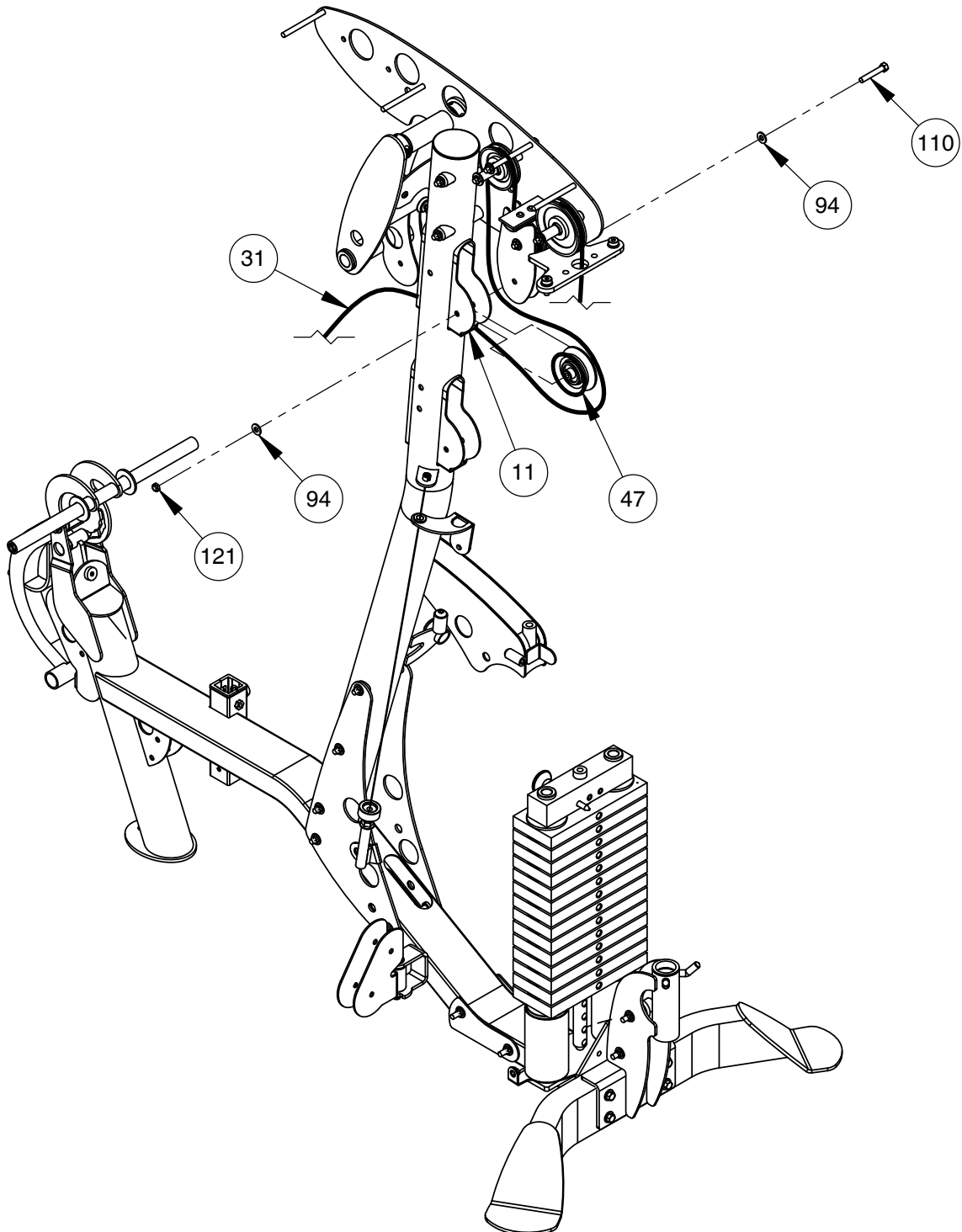

OWNER'S MANUAL

FRAME ASSEMBLY

NOTE:

- WRENCH TIGHTEN HARDWARE.
- SOME PARTS MAY HAVE BEEN REMOVED FOR CLARITY.
- INSTALL **CABLE** AND PULLEYS AT THE SAME TIME.

* THIS PART ORIGINALLY INCLUDED IN V-PRESS-ARM UNIT.

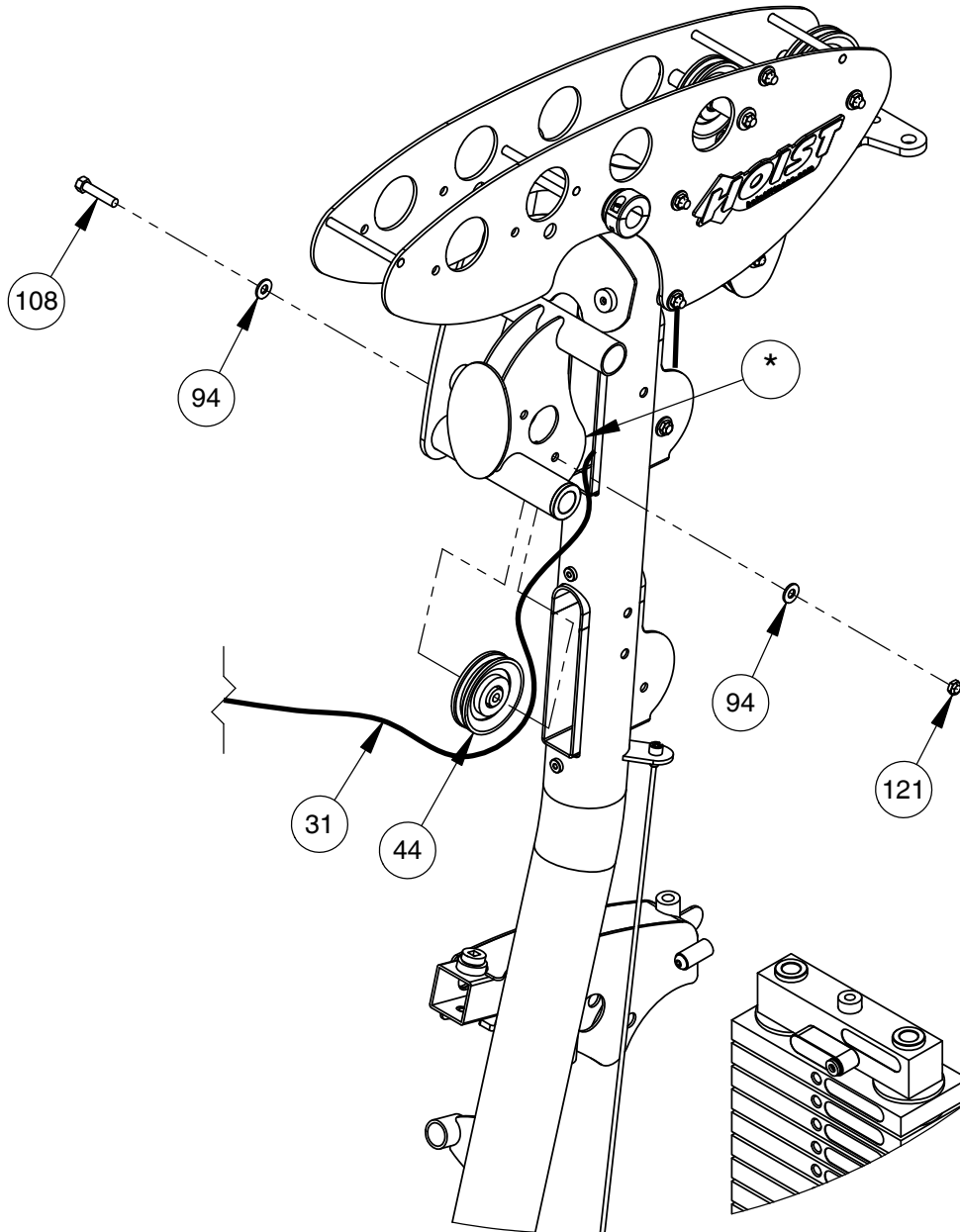

OWNER'S MANUAL

FRAME ASSEMBLY

PROPERLY INSTALLED VIEW

NOTE:

- WRENCH TIGHTEN HARDWARE.
- SOME PARTS MAY HAVE BEEN REMOVED FOR CLARITY.
- INSTALL **CABLE** AND PULLEYS AT THE SAME TIME.

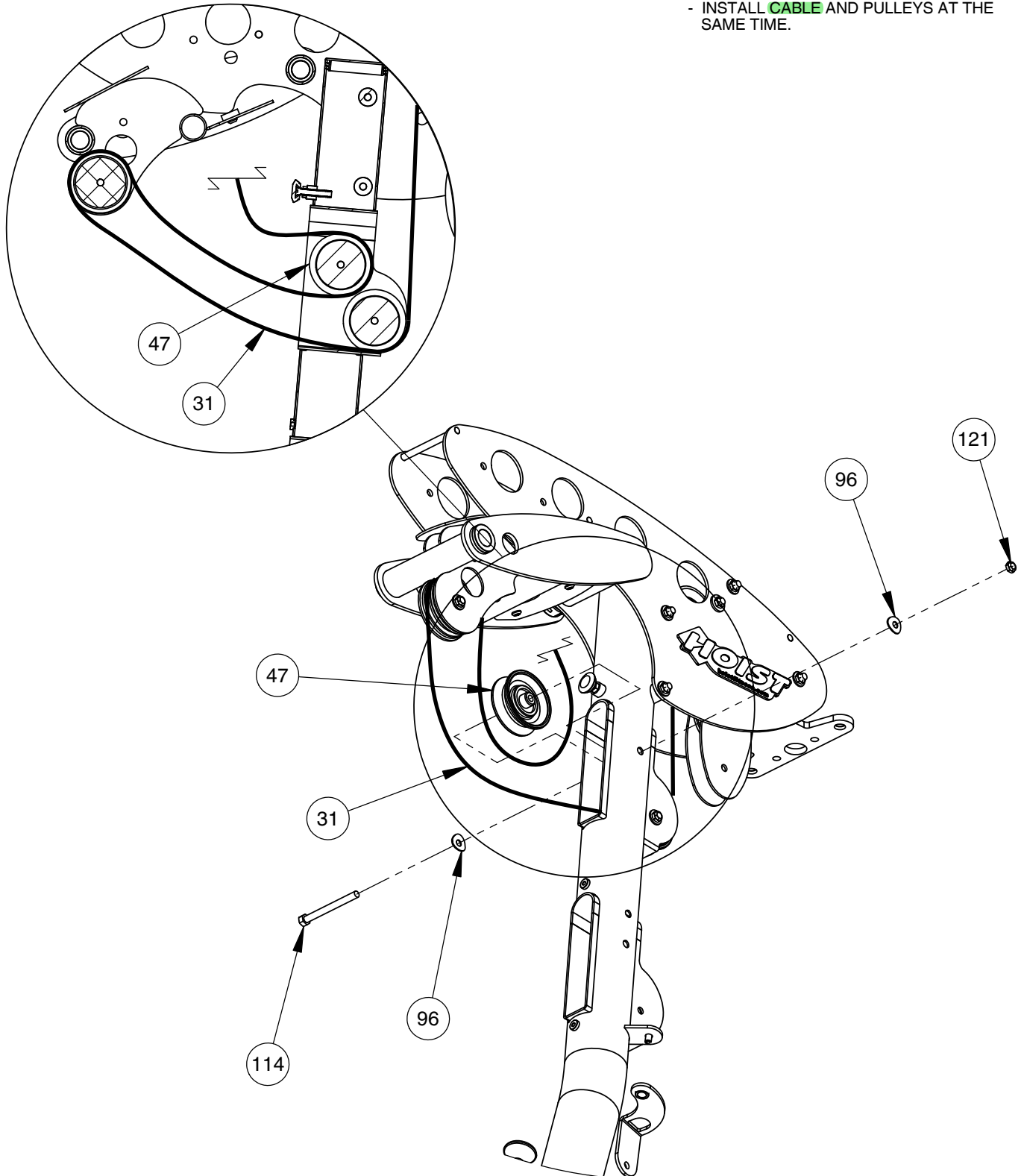

OWNER'S MANUAL

FRAME ASSEMBLY

PROPERLY INSTALLED VIEW

NOTE:

- WRENCH TIGHTEN HARDWARE.
- SOME PARTS MAY HAVE BEEN REMOVED FOR CLARITY.
- INSTALL **CABLE** AND PULLEYS AT THE SAME TIME.

* THIS PART ORIGINALLY INCLUDED IN V-PRESSARM UNIT.

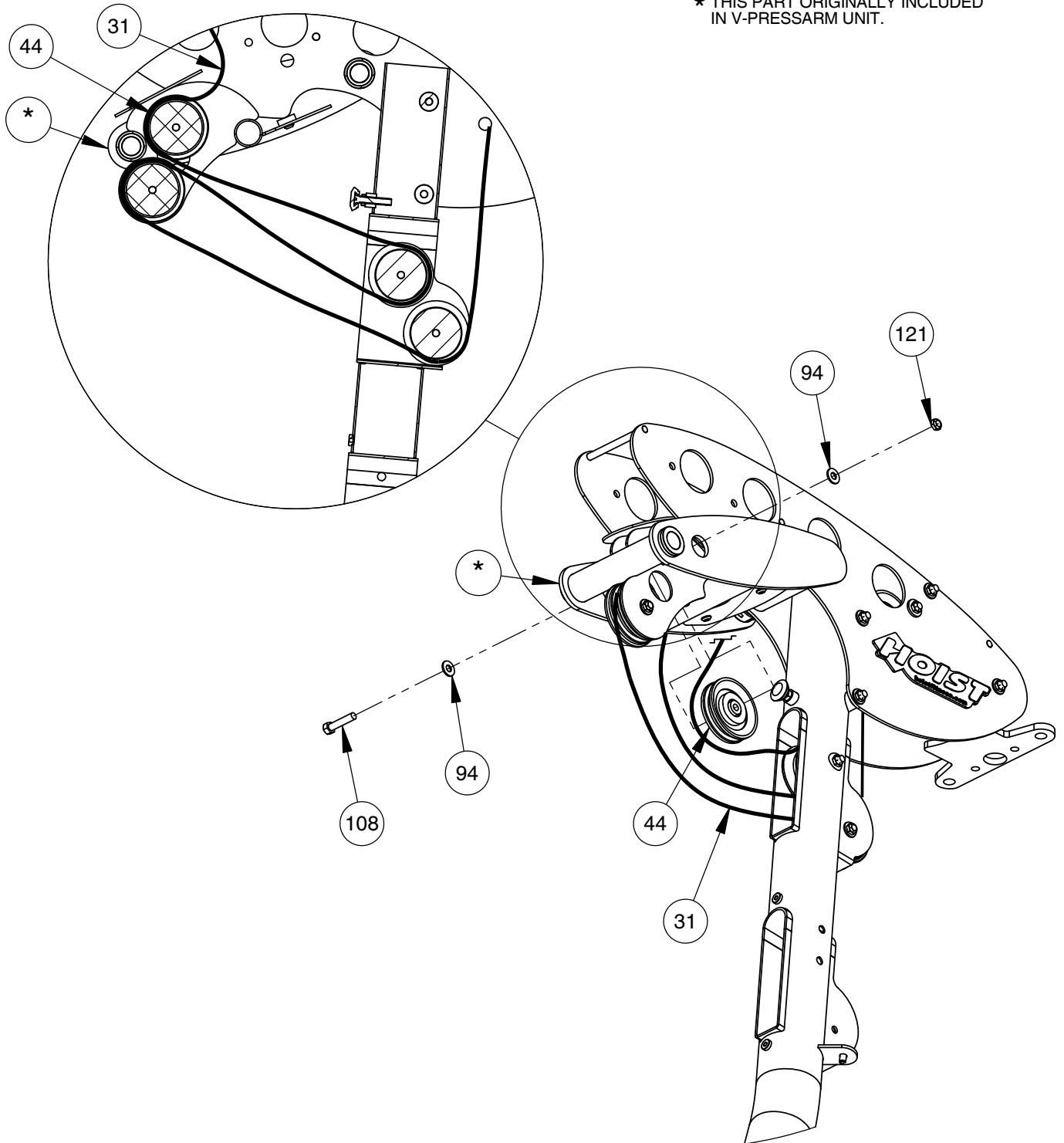

OWNER'S MANUAL

FRAME ASSEMBLY

NOTE:

- HAND TIGHTEN HARDWARE.
- SOME PARTS MAY HAVE BEEN REMOVED FOR CLARITY.
- INSTALL **CABLE** AND PULLEYS AT THE SAME TIME.

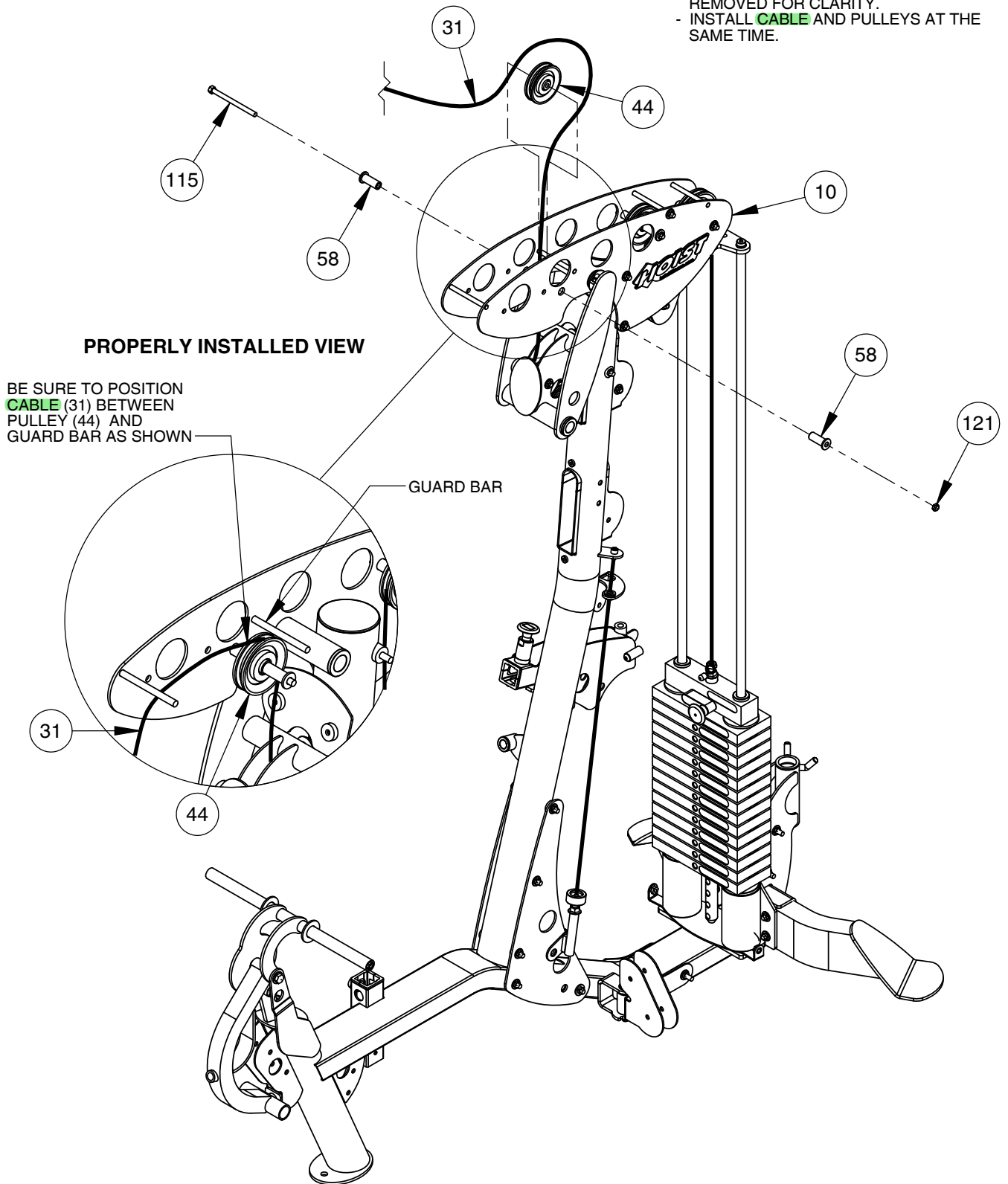

OWNER'S MANUAL

FRAME ASSEMBLY

NOTE:
- HAND TIGHTEN HARDWARE.
- SOME PARTS MAY HAVE BEEN
REMOVED FOR CLARITY.

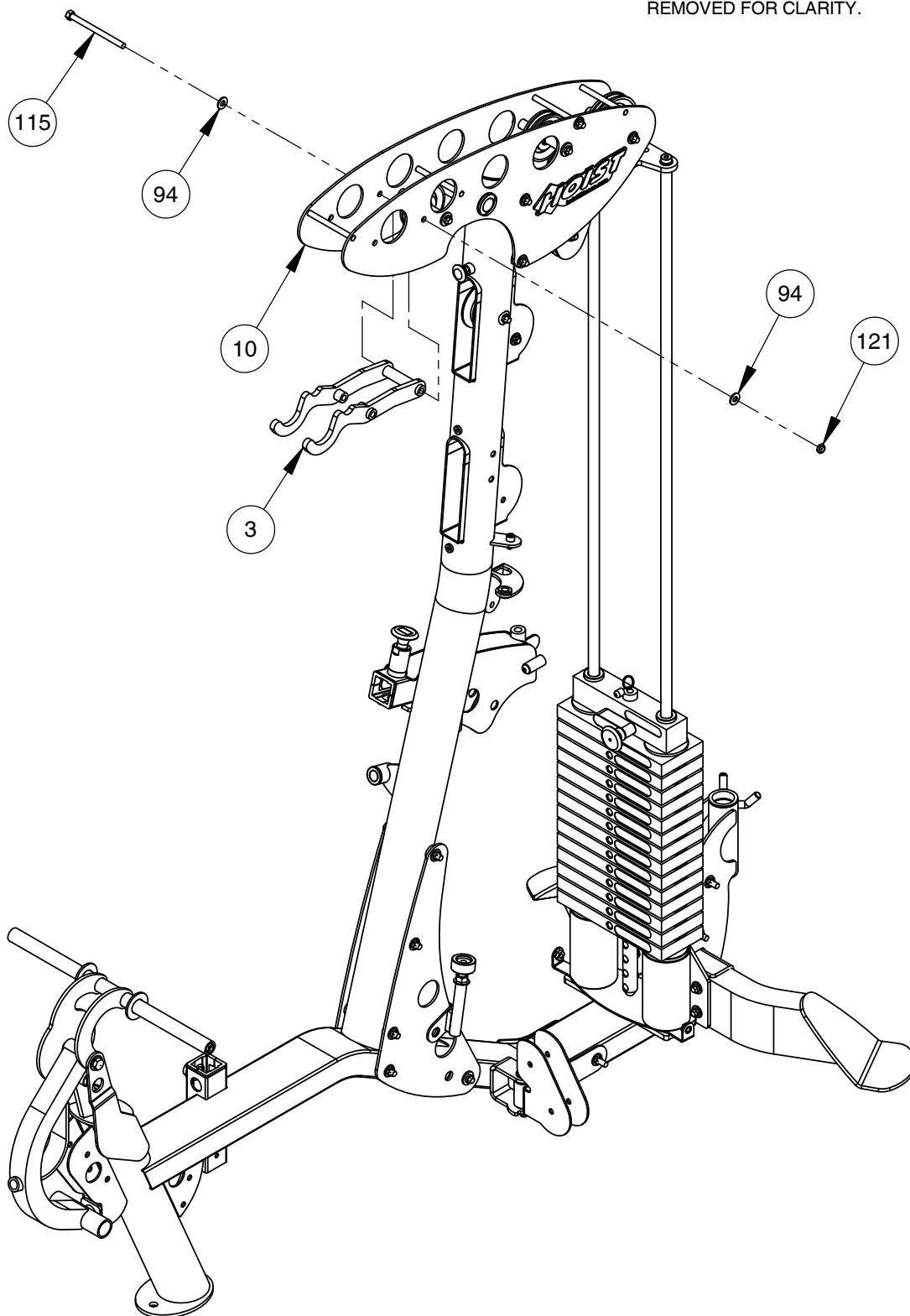

OWNER'S MANUAL

FRAME ASSEMBLY

NOTE:

- WRENCH TIGHTEN HARDWARE.
- SOME PARTS MAY HAVE BEEN REMOVED FOR CLARITY.
- INSTALL **CABLE** AND PULLEYS AT THE SAME TIME.

PROPERLY INSTALLED VIEW

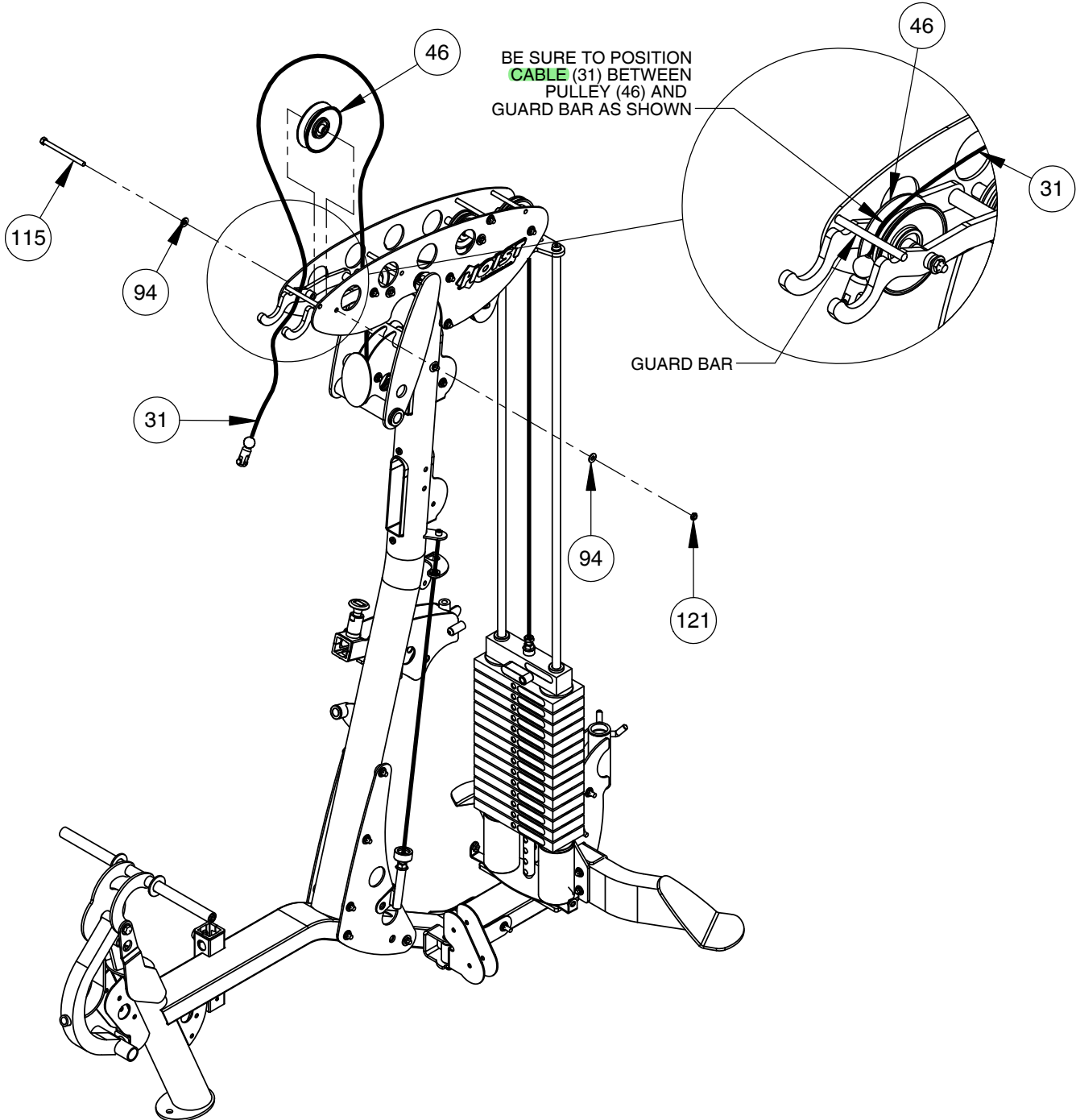

OWNER'S MANUAL

FRAME ASSEMBLY

NOTE:
- SOME PARTS MAY HAVE BEEN
REMOVED FOR CLARITY.

CABLING PROFILE VIEW

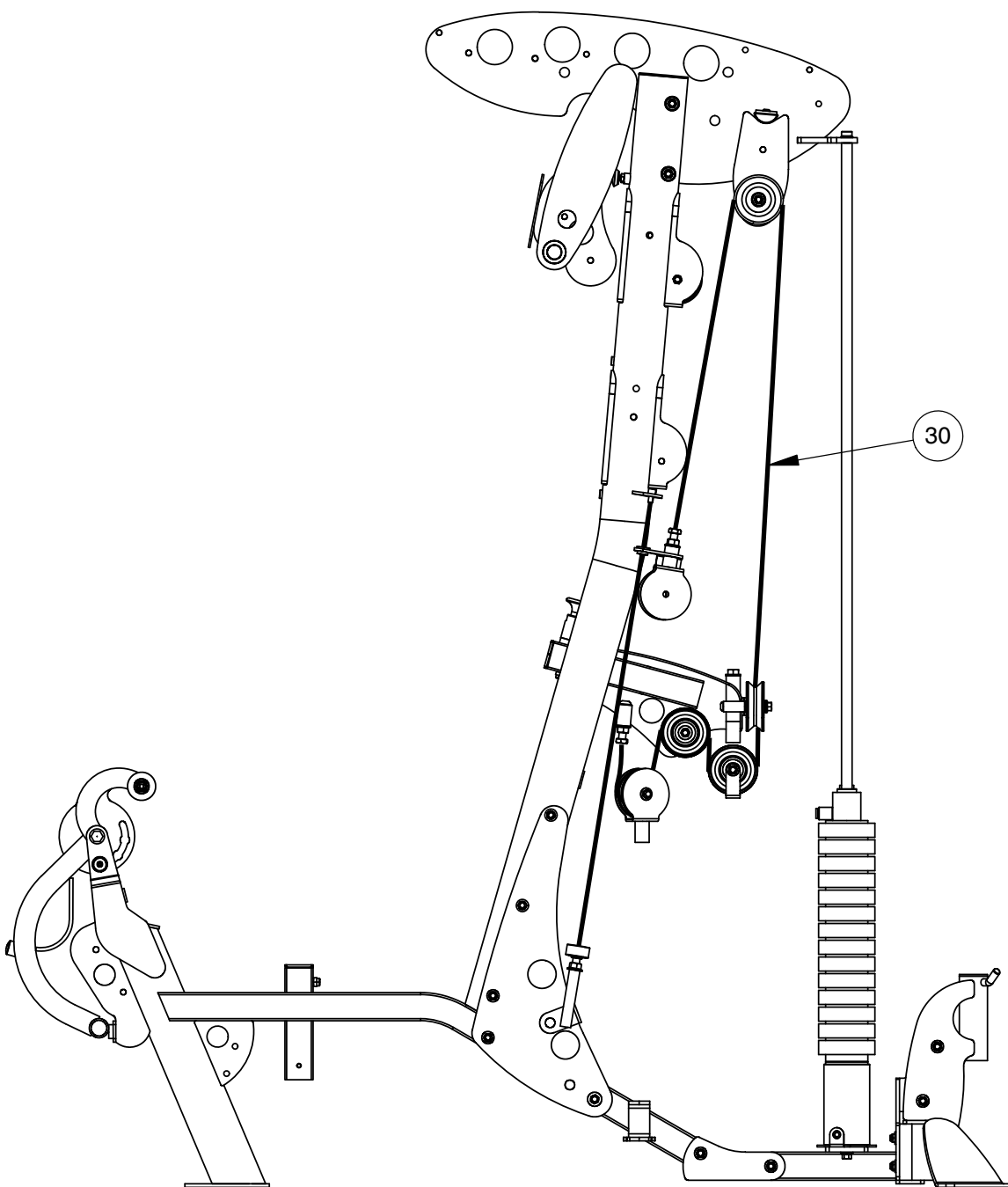

OWNER'S MANUAL

FRAME ASSEMBLY

NOTE:

- WRENCH TIGHTEN HARDWARE.
- SOME PARTS MAY HAVE BEEN REMOVED FOR CLARITY.
- INSTALL **CABLE** AND PULLEYS AT THE SAME TIME.

FINE TUNING:

LOOSEN JAM NUT AND THREAD BOLT IN/OUT TO GIVE THE **CABLE** PROPER TENSION. RE-TIGHTEN JAM NUT.

WARNING - CABLE BOLT MUST BE THREADED A MINIMUM OF 3/8" WITH JAM NUT TIGHTENED SECURELY TO ENSURE PROPER CONNECTION.

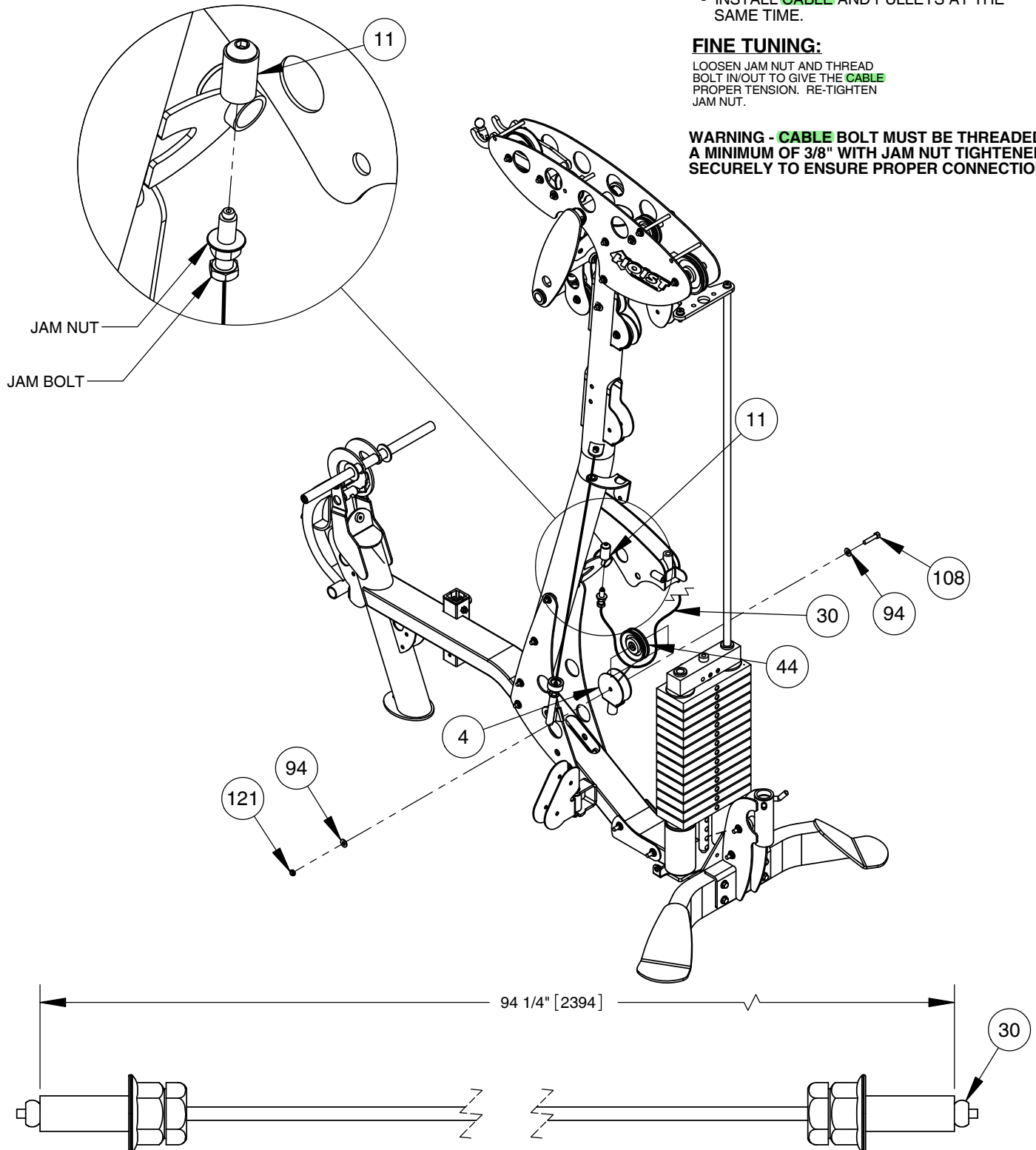

OWNER'S MANUAL

FRAME ASSEMBLY

NOTE:

- WRENCH TIGHTEN HARDWARE.
- SOME PARTS MAY HAVE BEEN REMOVED FOR CLARITY.
- INSTALL **CABLE** AND PULLEYS AT THE SAME TIME.

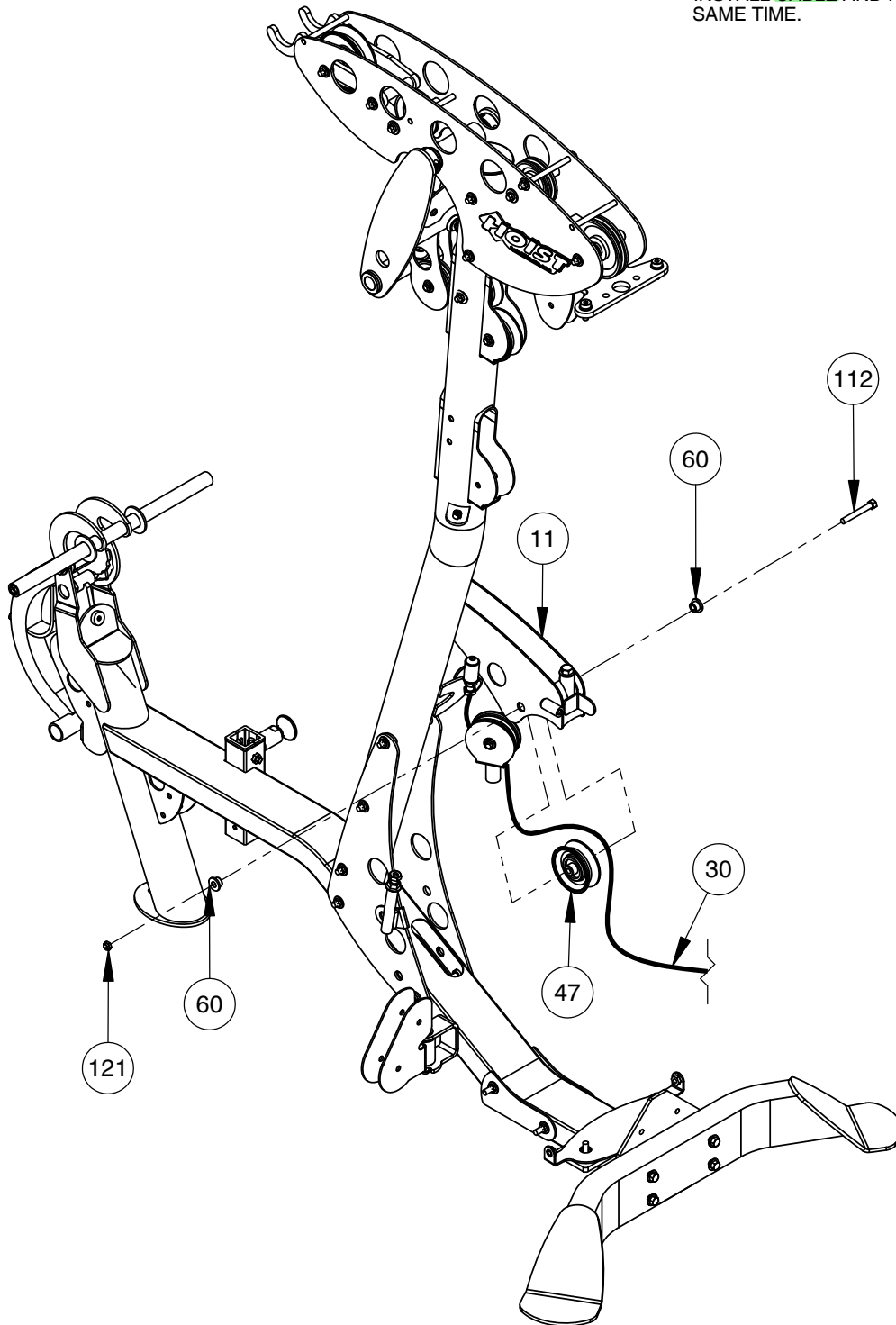

OWNER'S MANUAL

FRAME ASSEMBLY

NOTE:

- WRENCH TIGHTEN HARDWARE.
- SOME PARTS MAY HAVE BEEN REMOVED FOR CLARITY.
- INSTALL **CABLE** AND PULLEYS AT THE SAME TIME.

PROPERLY INSTALLED VIEW

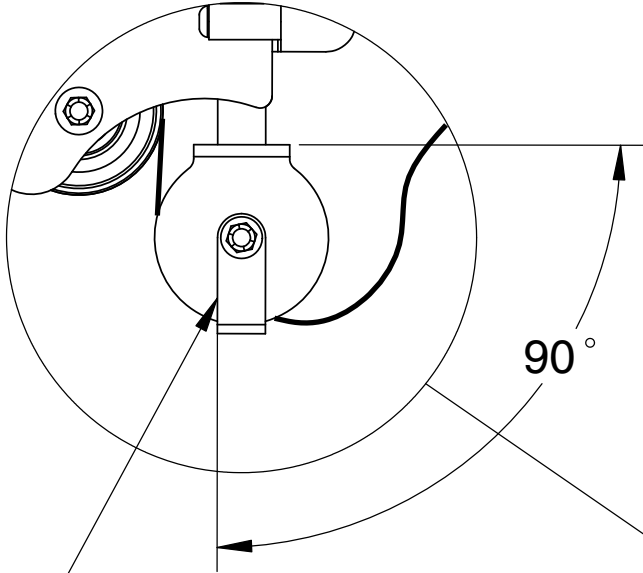

BE SURE PULLEY BRACKET (71) IS INSTALLED AT A RIGHT ANGLE, AS SHOWN.

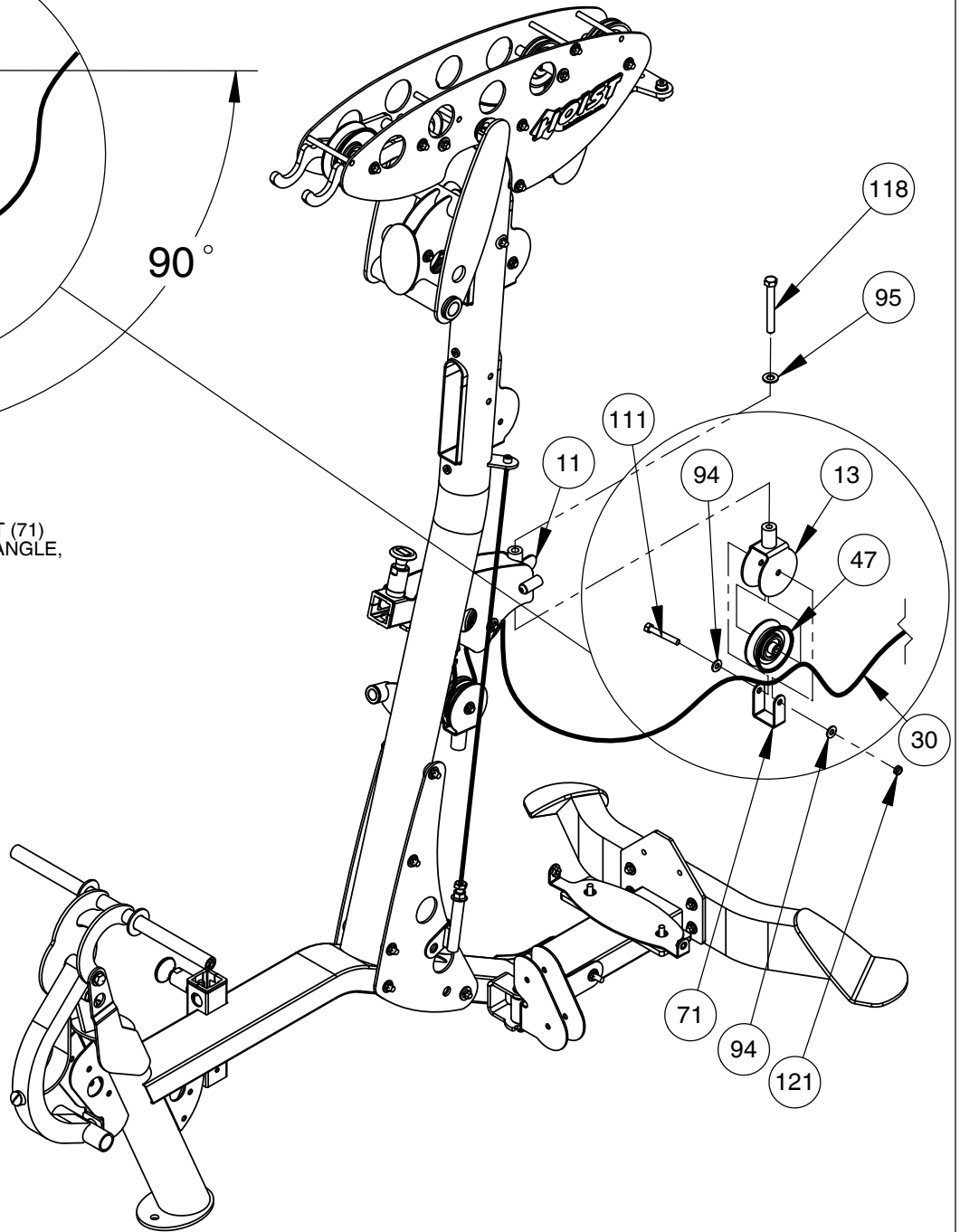

OWNER'S MANUAL

FRAME ASSEMBLY

NOTE:

- WRENCH TIGHTEN HARDWARE.
- SOME PARTS MAY HAVE BEEN REMOVED FOR CLARITY.
- INSTALL **CABLE** AND PULLEYS AT THE SAME TIME.

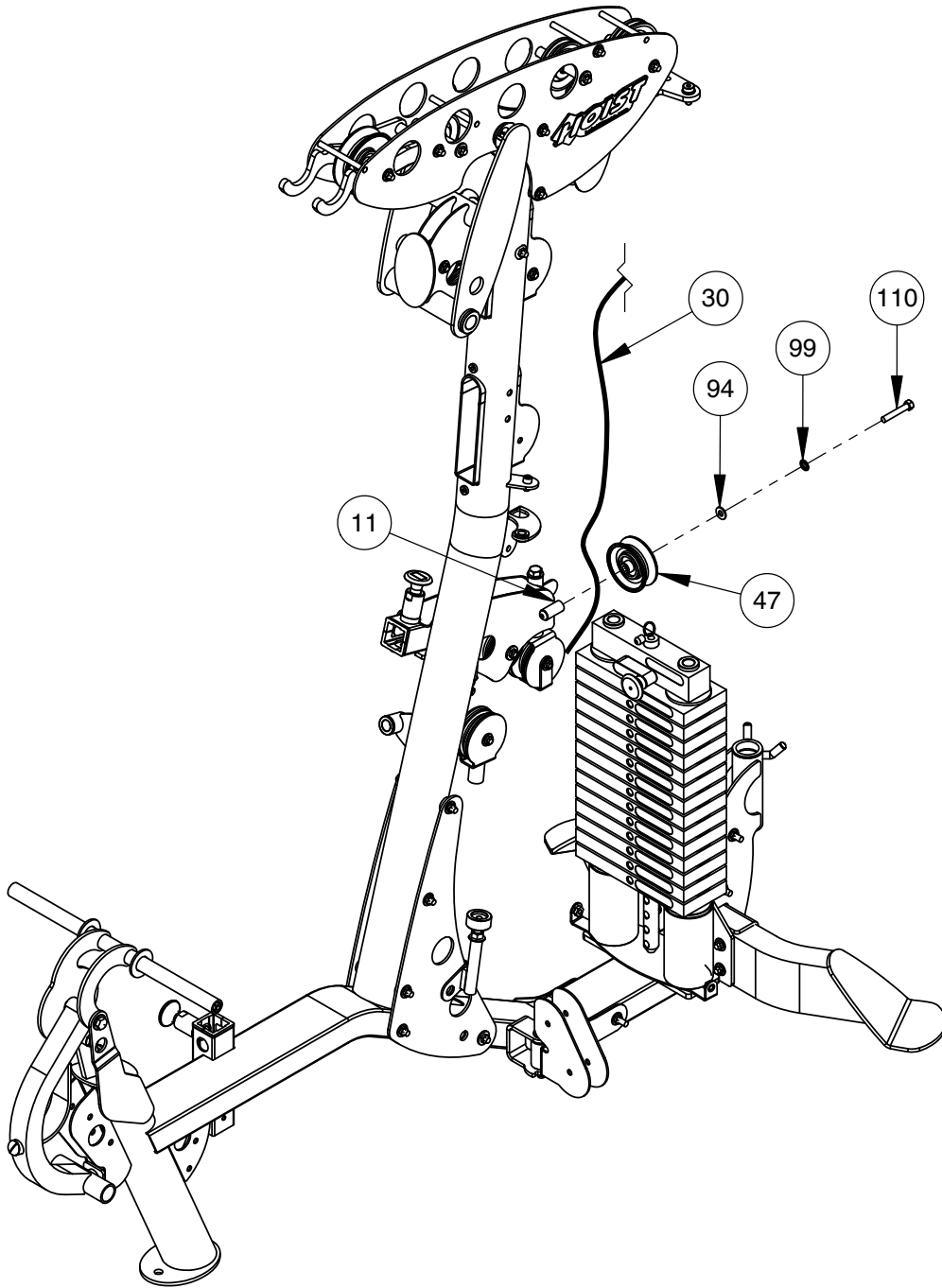

OWNER'S MANUAL

FRAME ASSEMBLY

NOTE:

- WRENCH TIGHTEN HARDWARE.
- SOME PARTS MAY HAVE BEEN REMOVED FOR CLARITY.
- INSTALL **CABLE** AND PULLEYS AT THE SAME TIME.

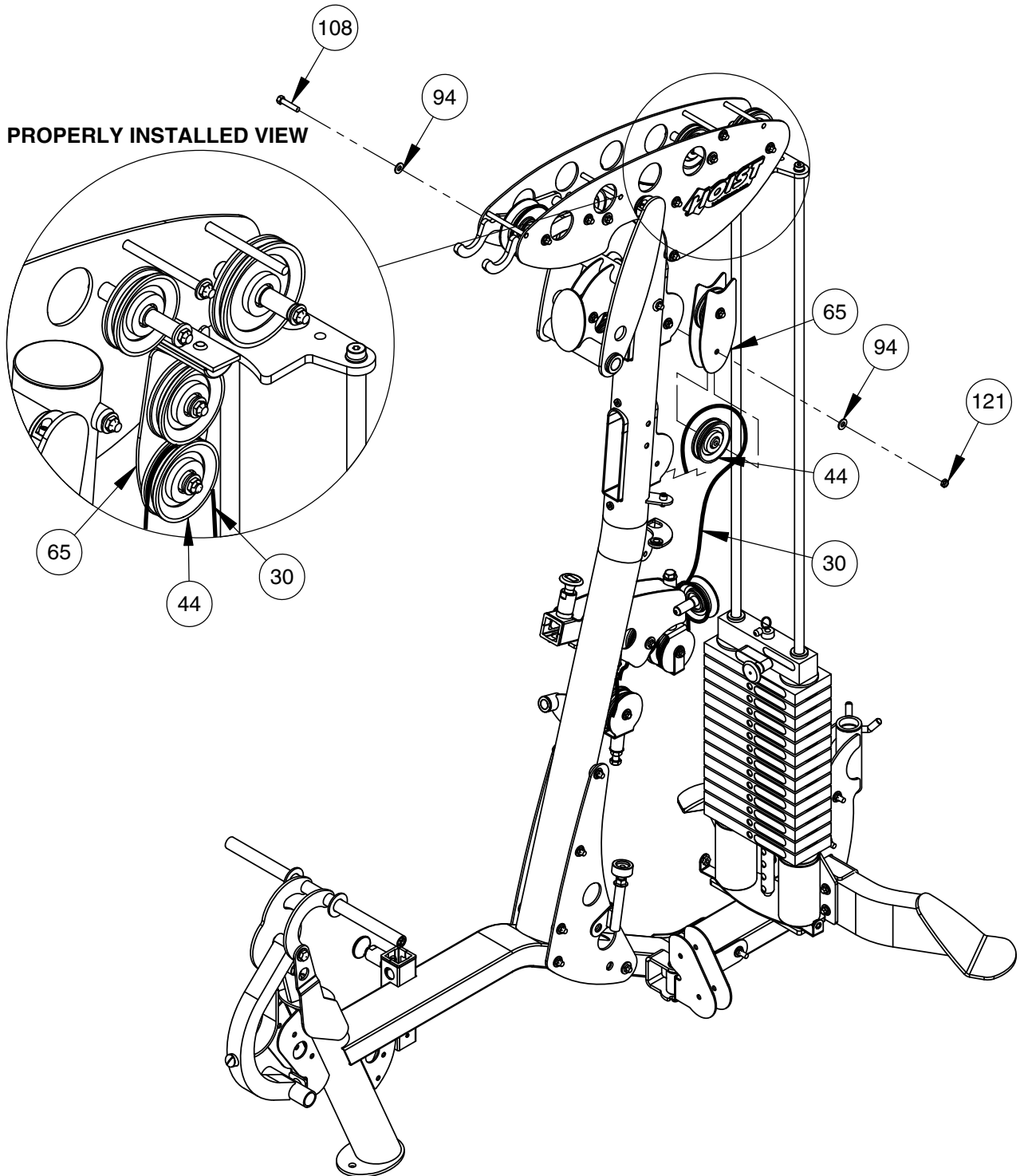

OWNER'S MANUAL

FRAME ASSEMBLY

NOTE:

- WRENCH TIGHTEN HARDWARE.
- SOME PARTS MAY HAVE BEEN REMOVED FOR CLARITY.
- INSTALL **CABLE** AND PULLEYS AT THE SAME TIME.

FINE TUNING:

LOOSEN JAM NUT AND THREAD BOLT IN/OUT TO GIVE THE **CABLE** PROPER TENSION. RE-TIGHTEN JAM NUT.

WARNING - CABLE BOLT MUST BE THREADED A MINIMUM OF 3/8" WITH JAM NUT TIGHTENED SECURELY TO ENSURE PROPER CONNECTION.

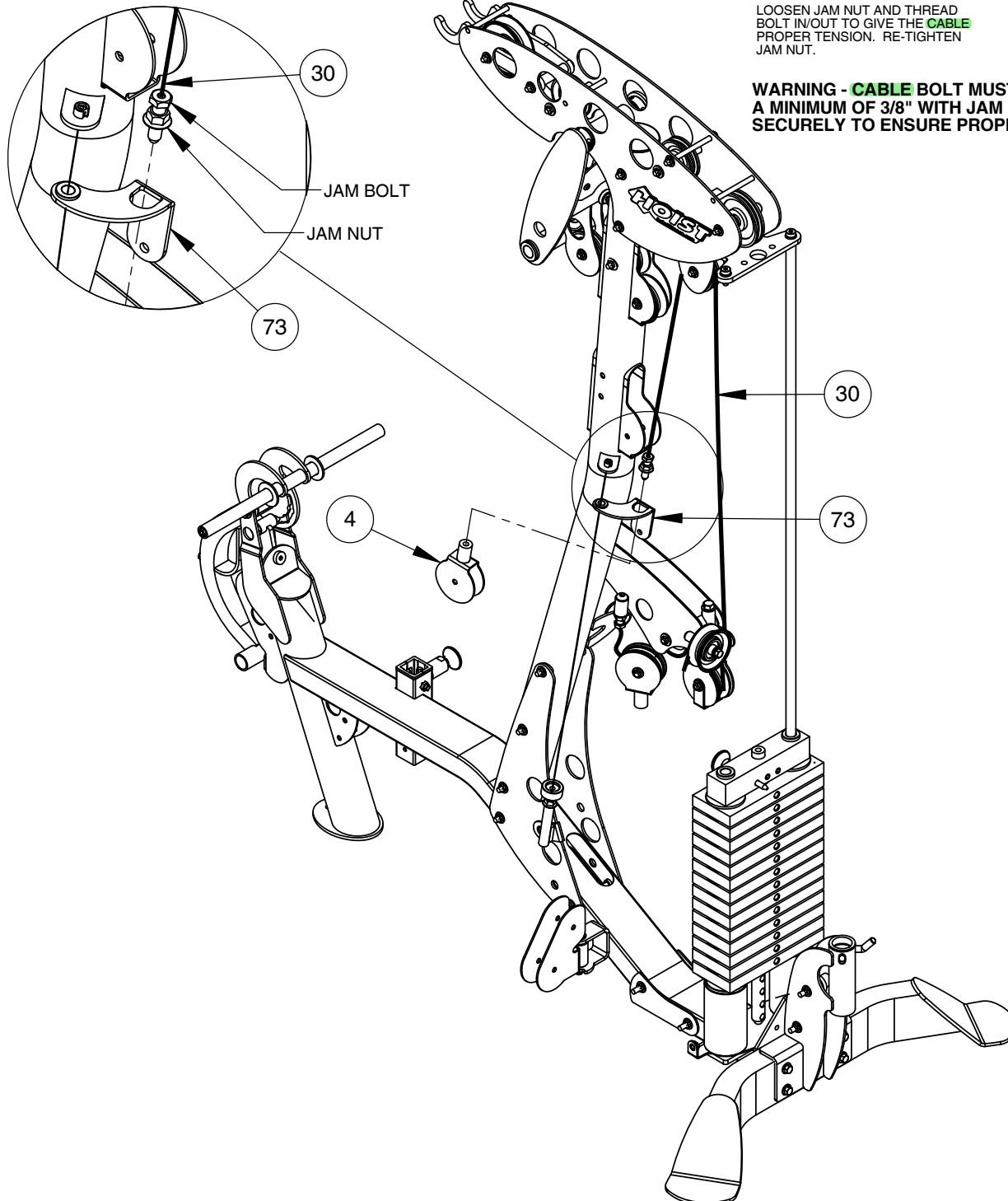

OWNER'S MANUAL

FRAME ASSEMBLY

NOTE:
- SOME PARTS MAY HAVE BEEN
REMOVED FOR CLARITY.

CABLING PROFILE VIEW

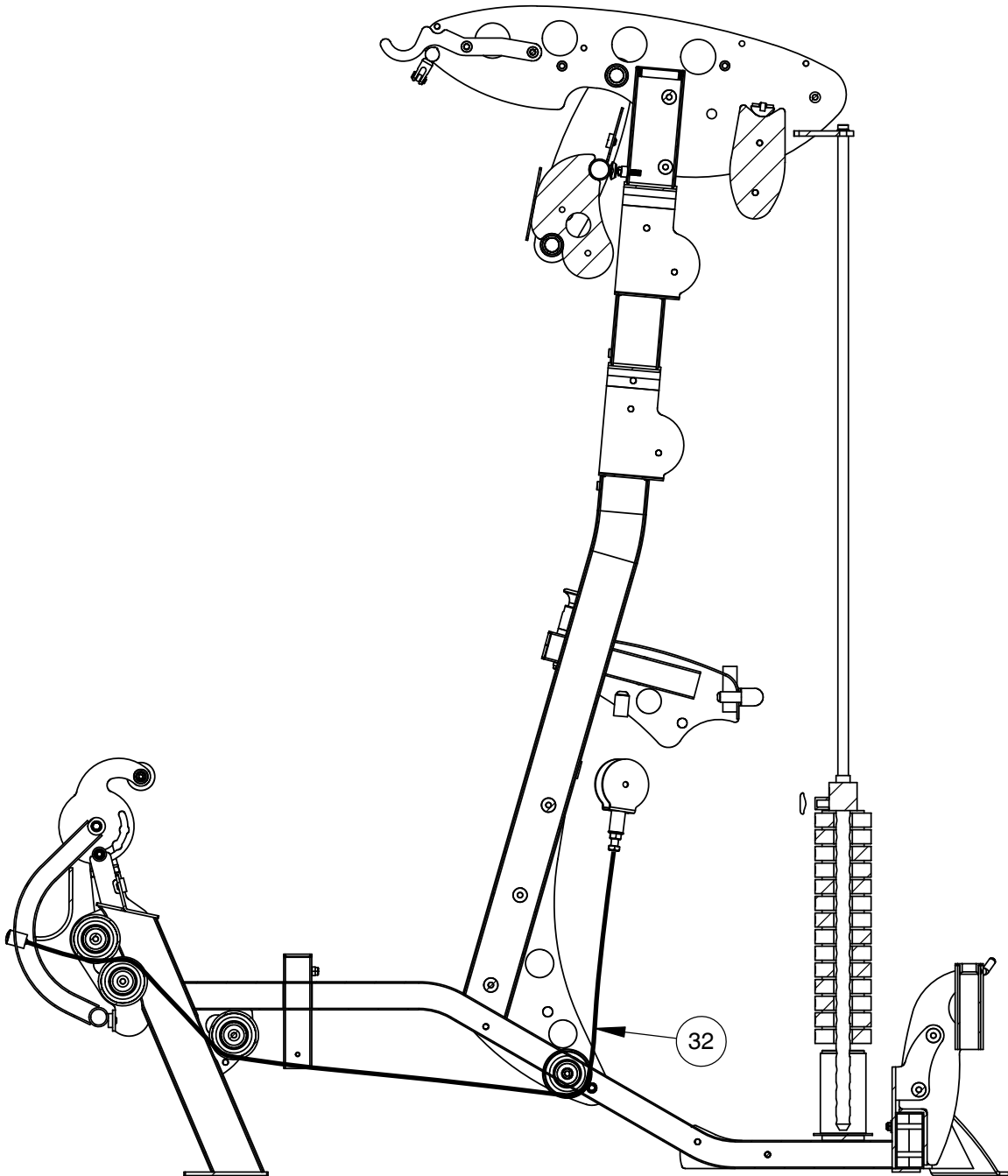

OWNER'S MANUAL

FRAME ASSEMBLY

- NOTE:
- HAND TIGHTEN HARDWARE.
 - SOME PARTS MAY HAVE BEEN REMOVED FOR CLARITY.

PROPERLY INSTALLED VIEW

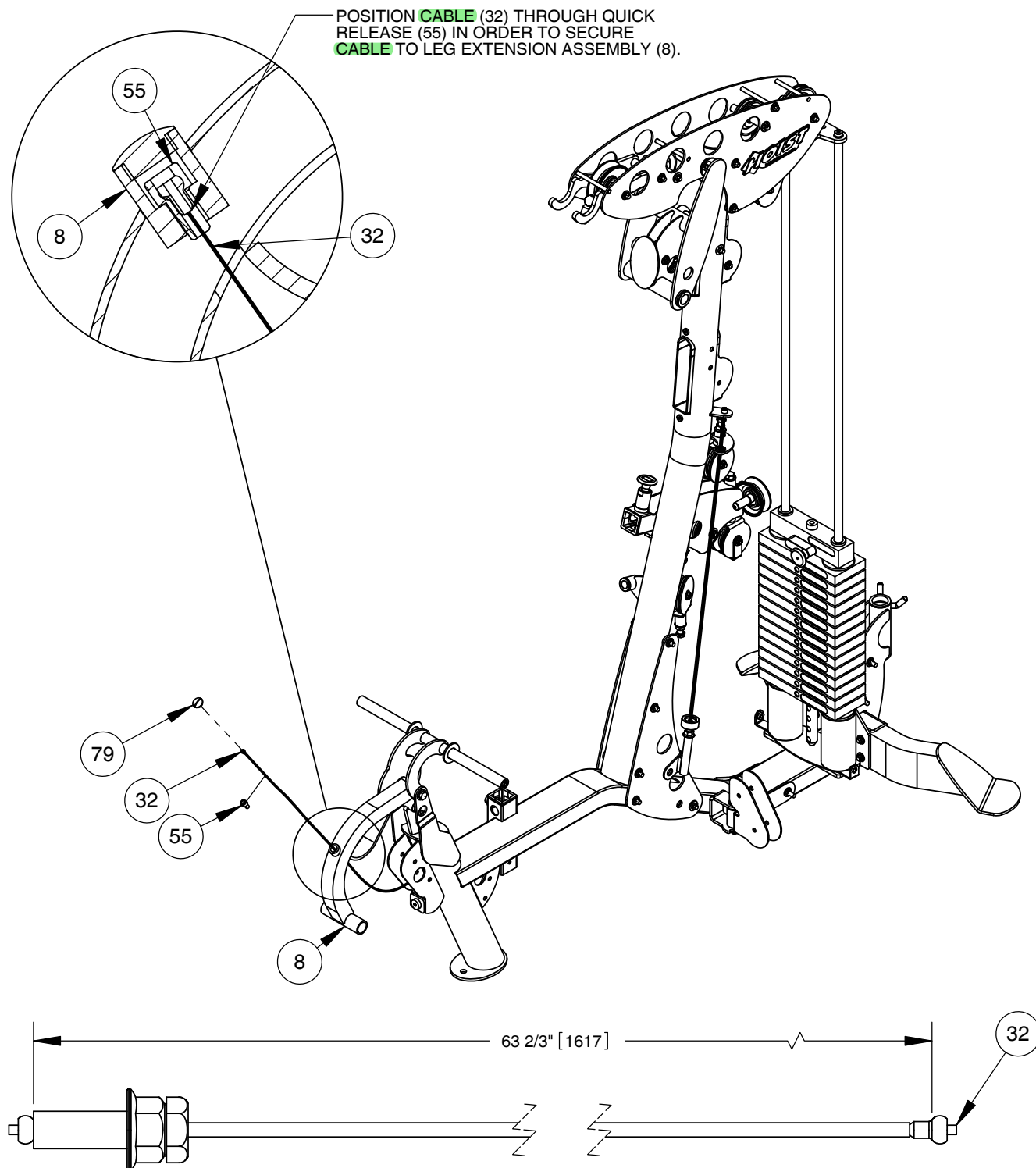

OWNER'S MANUAL

FRAME ASSEMBLY

NOTE:

- WRENCH TIGHTEN HARDWARE.
- SOME PARTS MAY HAVE BEEN REMOVED FOR CLARITY.
- INSTALL **CABLE** AND PULLEYS AT THE SAME TIME.

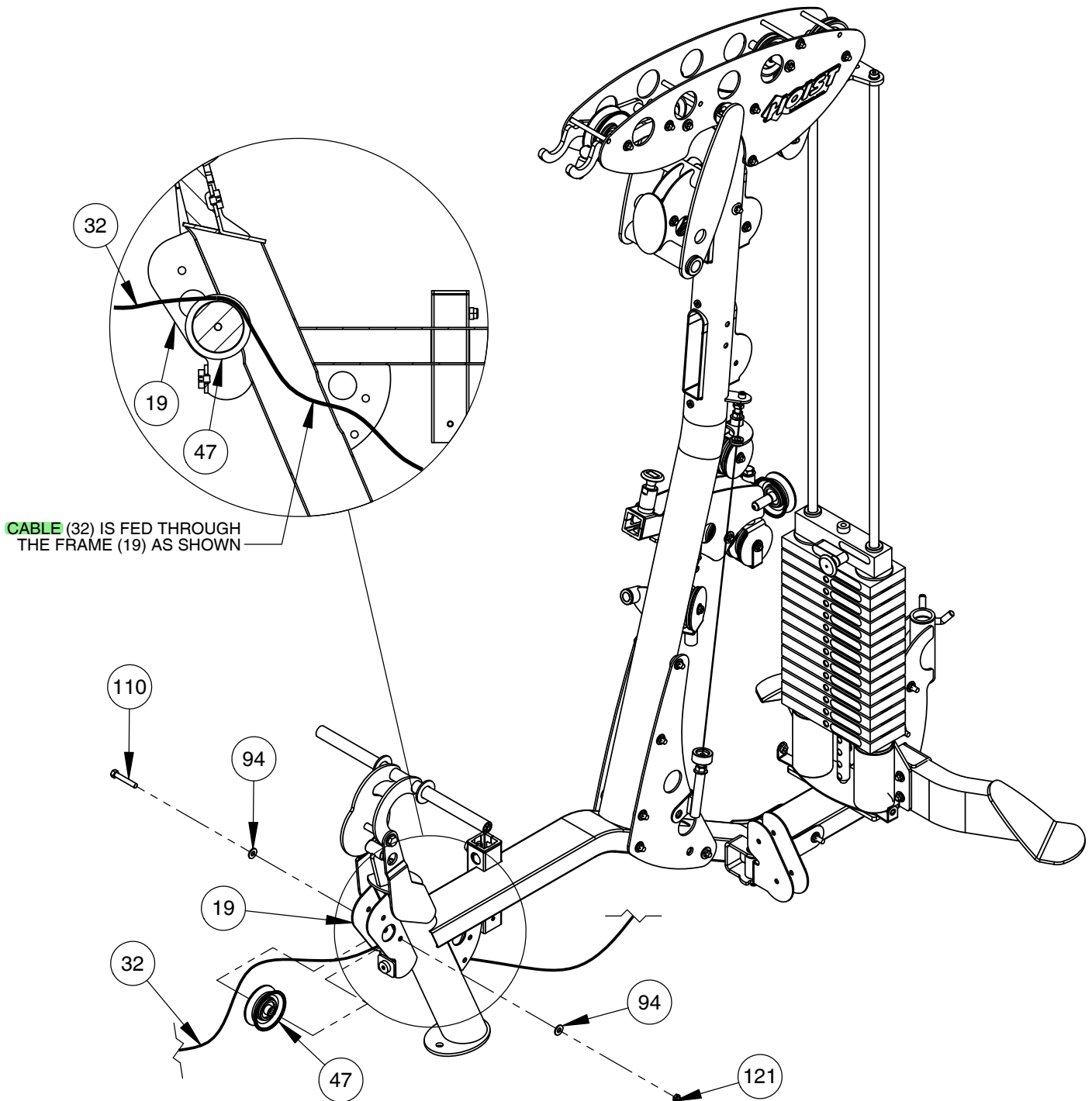

OWNER'S MANUAL

FRAME ASSEMBLY

NOTE:

- WRENCH TIGHTEN HARDWARE.
- SOME PARTS MAY HAVE BEEN REMOVED FOR CLARITY.
- INSTALL **CABLE** AND PULLEYS AT THE SAME TIME.

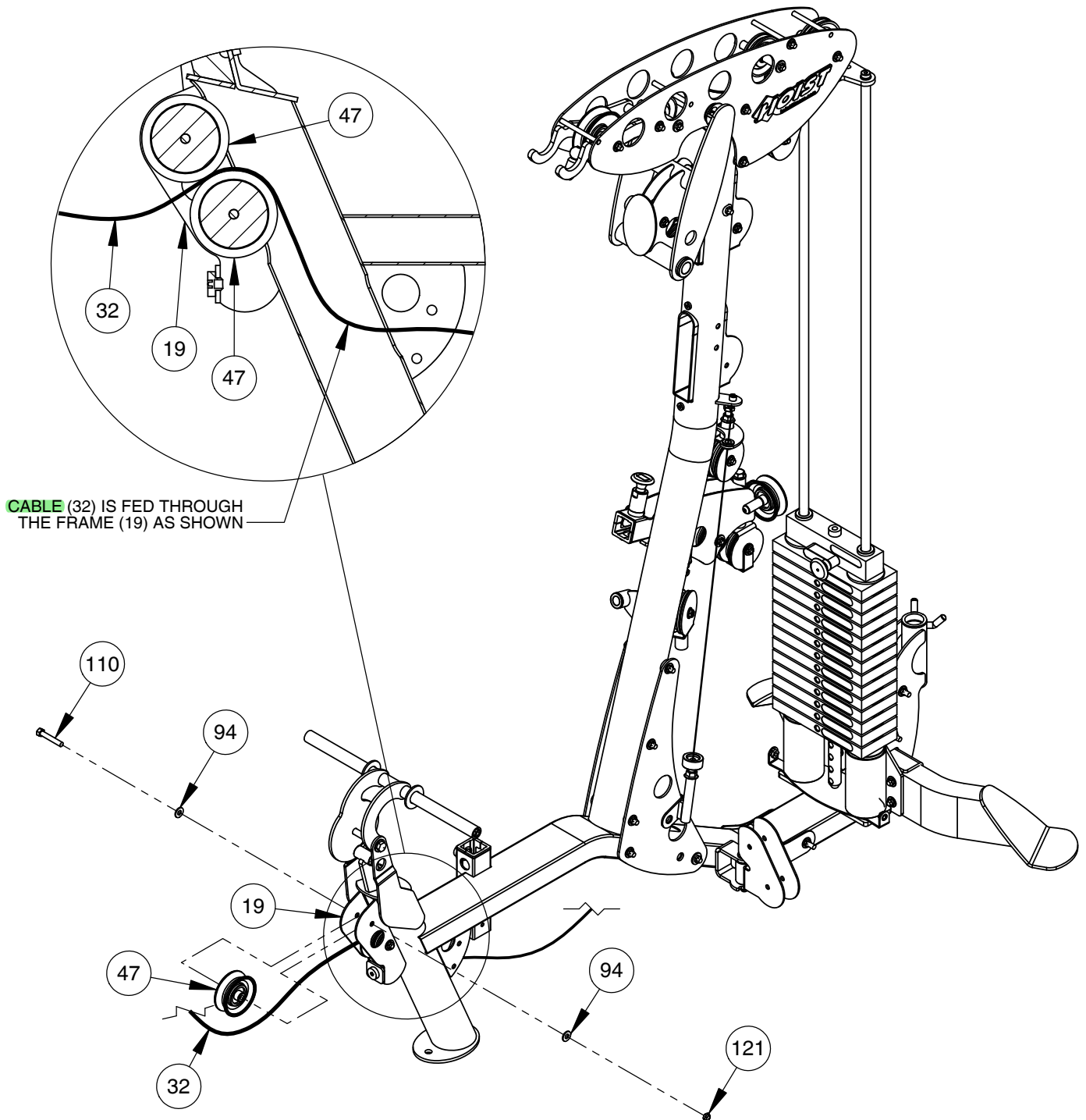

OWNER'S MANUAL

FRAME ASSEMBLY

NOTE:

- WRENCH TIGHTEN HARDWARE.
- SOME PARTS MAY HAVE BEEN REMOVED FOR CLARITY.
- INSTALL **CABLE** AND PULLEYS AT THE SAME TIME.

CABLE (32) IS FED THROUGH THE FRAME (19) IN PREVIOUS STEPS AS SHOWN

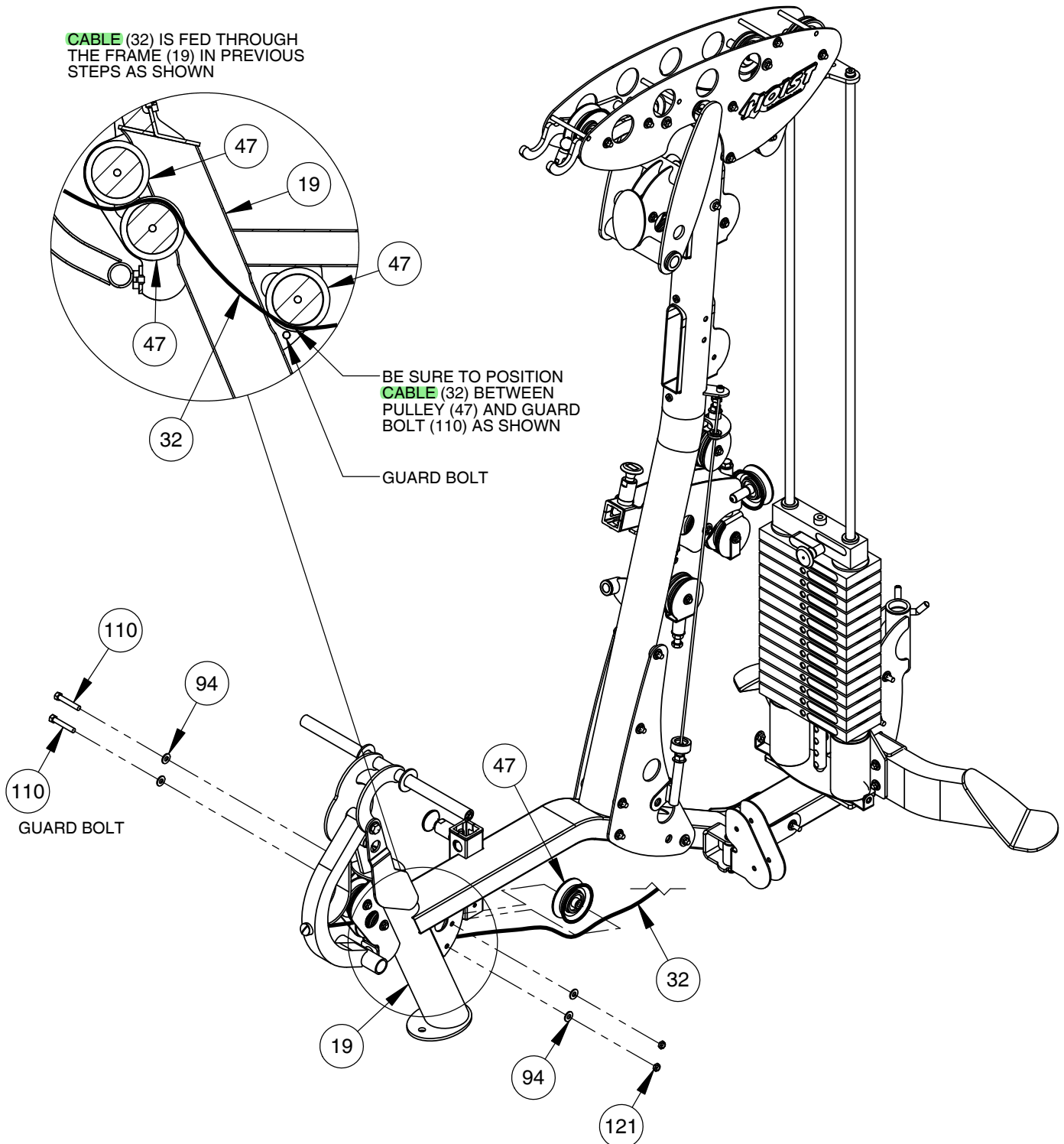

OWNER'S MANUAL

FRAME ASSEMBLY

NOTE:

- WRENCH TIGHTEN HARDWARE.
- SOME PARTS MAY HAVE BEEN REMOVED FOR CLARITY.
- INSTALL **CABLE** AND PULLEYS AT THE SAME TIME.

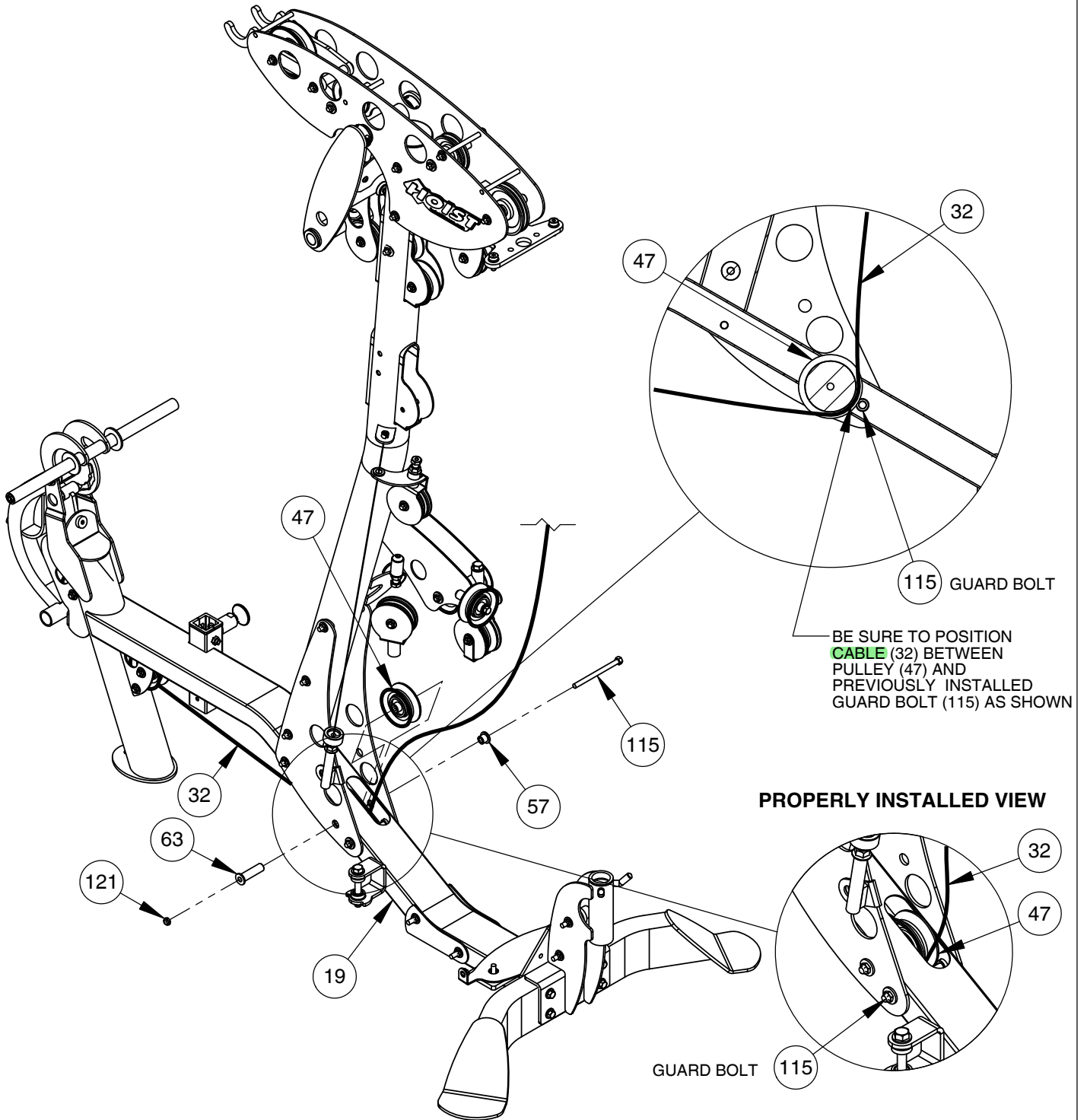

OWNER'S MANUAL

FRAME ASSEMBLY

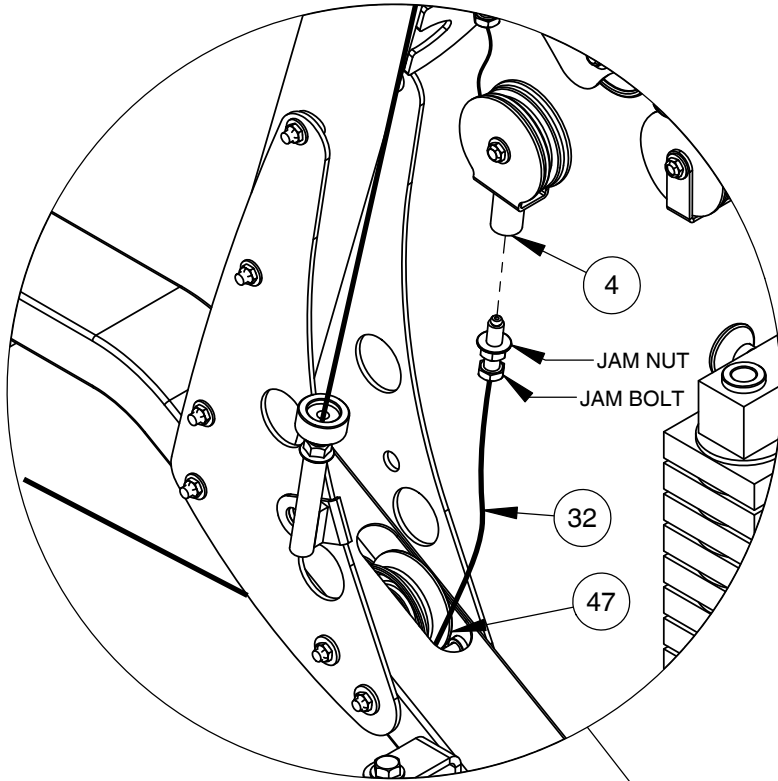

NOTE:

- SOME PARTS MAY HAVE BEEN REMOVED FOR CLARITY.
- INSTALL **CABLE** AND PULLEYS AT THE SAME TIME.
- WRENCH TIGHTEN **CABLE** ASSEMBLY (32) TO SECURE ONTO (4).

FINE TUNING:

LOOSEN JAM NUT AND THREAD BOLT IN/OUT TO GIVE THE **CABLE** PROPER TENSION. RE-TIGHTEN JAM NUT.

WARNING - CABLE BOLT MUST BE THREADED A MINIMUM OF 3/8" WITH JAM NUT TIGHTENED SECURELY TO ENSURE PROPER CONNECTION.

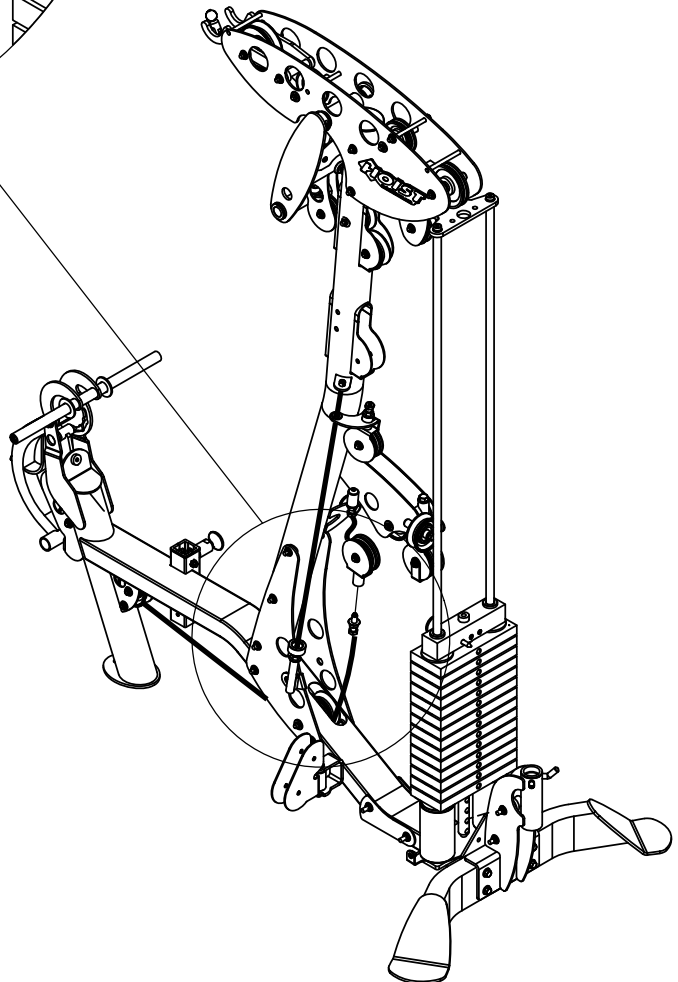

OWNER'S MANUAL

FRAME ASSEMBLY

NOTE:
- SOME PARTS MAY HAVE BEEN
REMOVED FOR CLARITY.

CABLING PROFILE VIEW

IMPORTANT:

If you are installing a V HI-LO Option, do not install **29**. Refer to the V HI-LO owner's manual and follow assembly steps to install **CABLE ASSEMBLY: V HI-LO AB 167.91" LG.** (item #1 in V HI-LO owner's manual) in place of **29**.

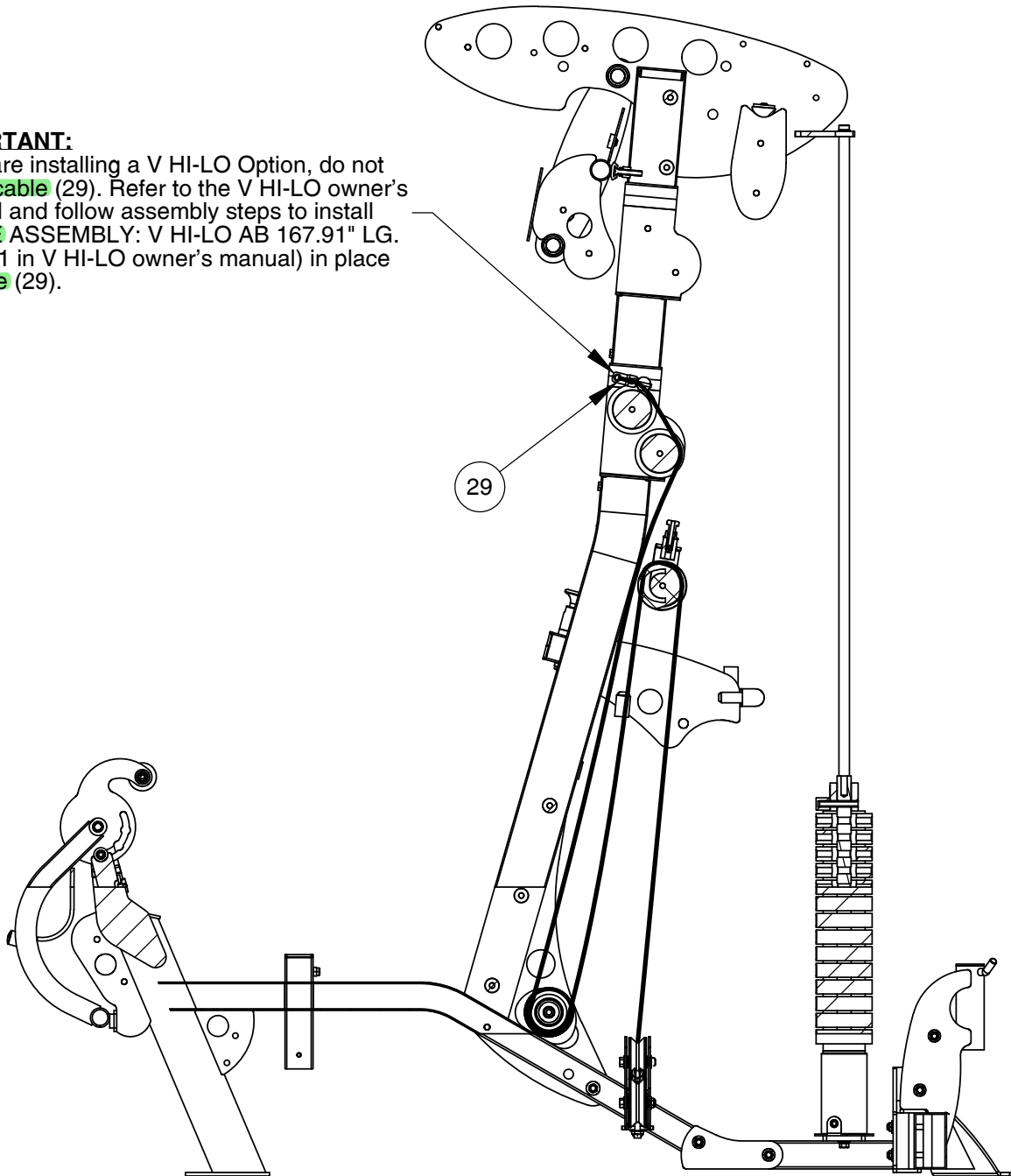

OWNER'S MANUAL

FRAME ASSEMBLY

NOTE:
- SOME PARTS MAY HAVE BEEN
REMOVED FOR CLARITY.
- WRENCH TIGHTEN HARDWARE.

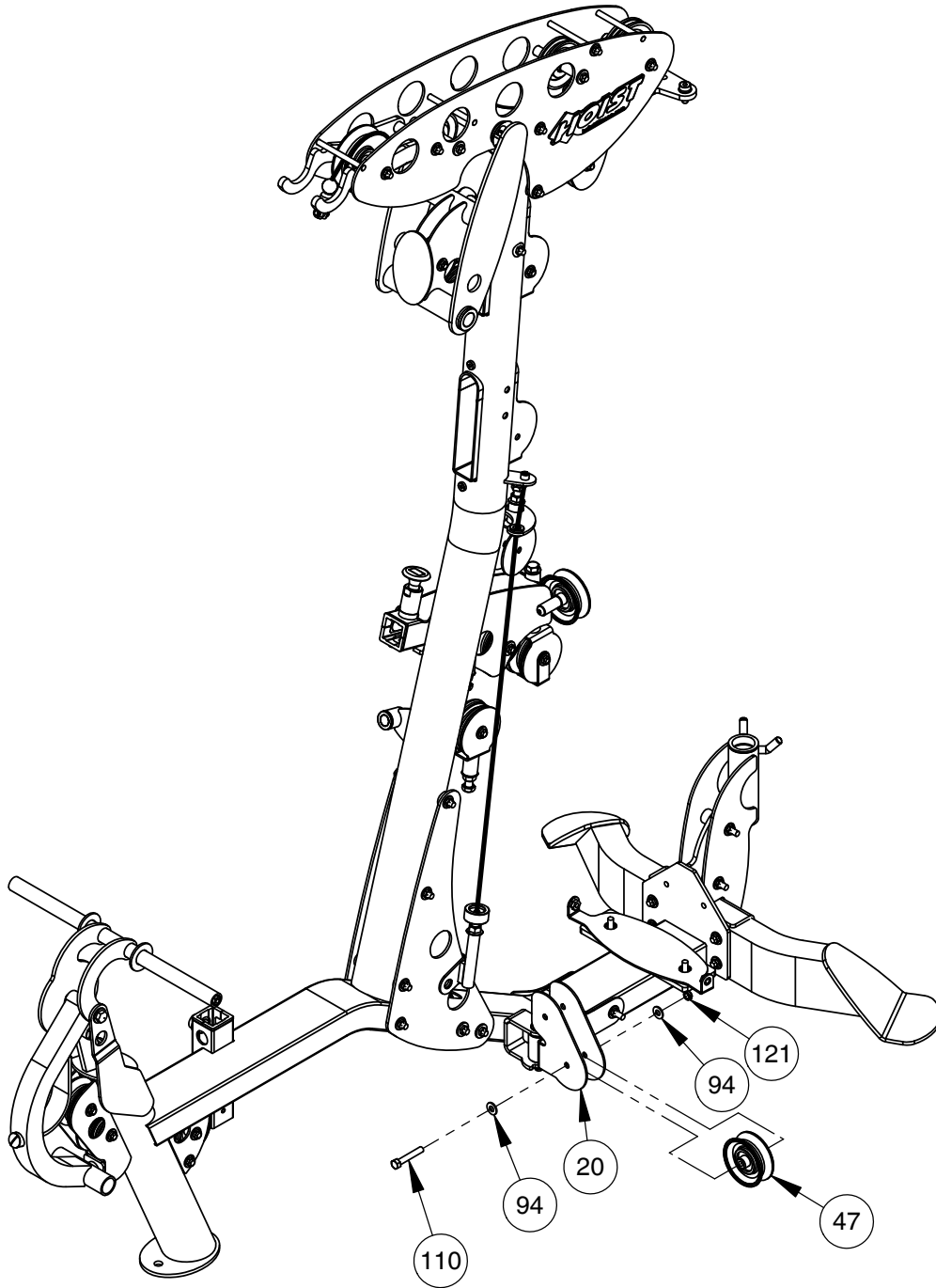

OWNER'S MANUAL

FRAME ASSEMBLY

- NOTE:
- SOME PARTS MAY HAVE BEEN REMOVED FOR CLARITY.
 - INSTALL **CABLE** AND PULLEYS AT THE SAME TIME.
 - WRENCH TIGHTEN HARDWARE.

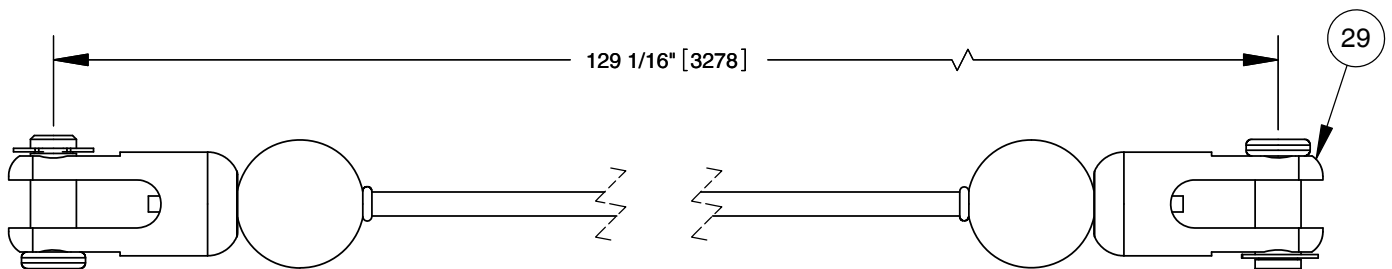
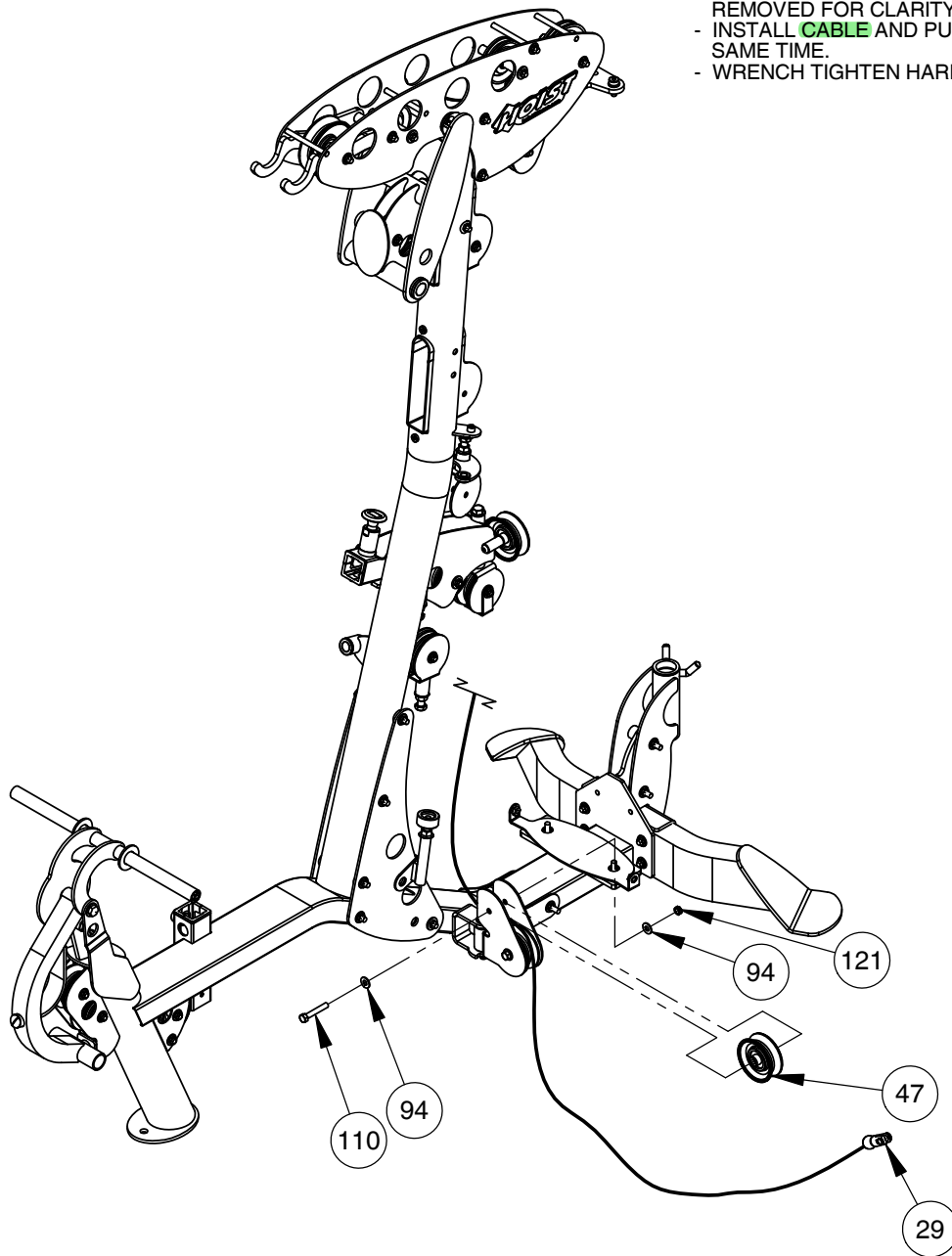

OWNER'S MANUAL

FRAME ASSEMBLY

NOTE:

- SOME PARTS MAY HAVE BEEN REMOVED FOR CLARITY.
- INSTALL **CABLE** AND PULLEYS AT THE SAME TIME.
- WRENCH TIGHTEN HARDWARE.

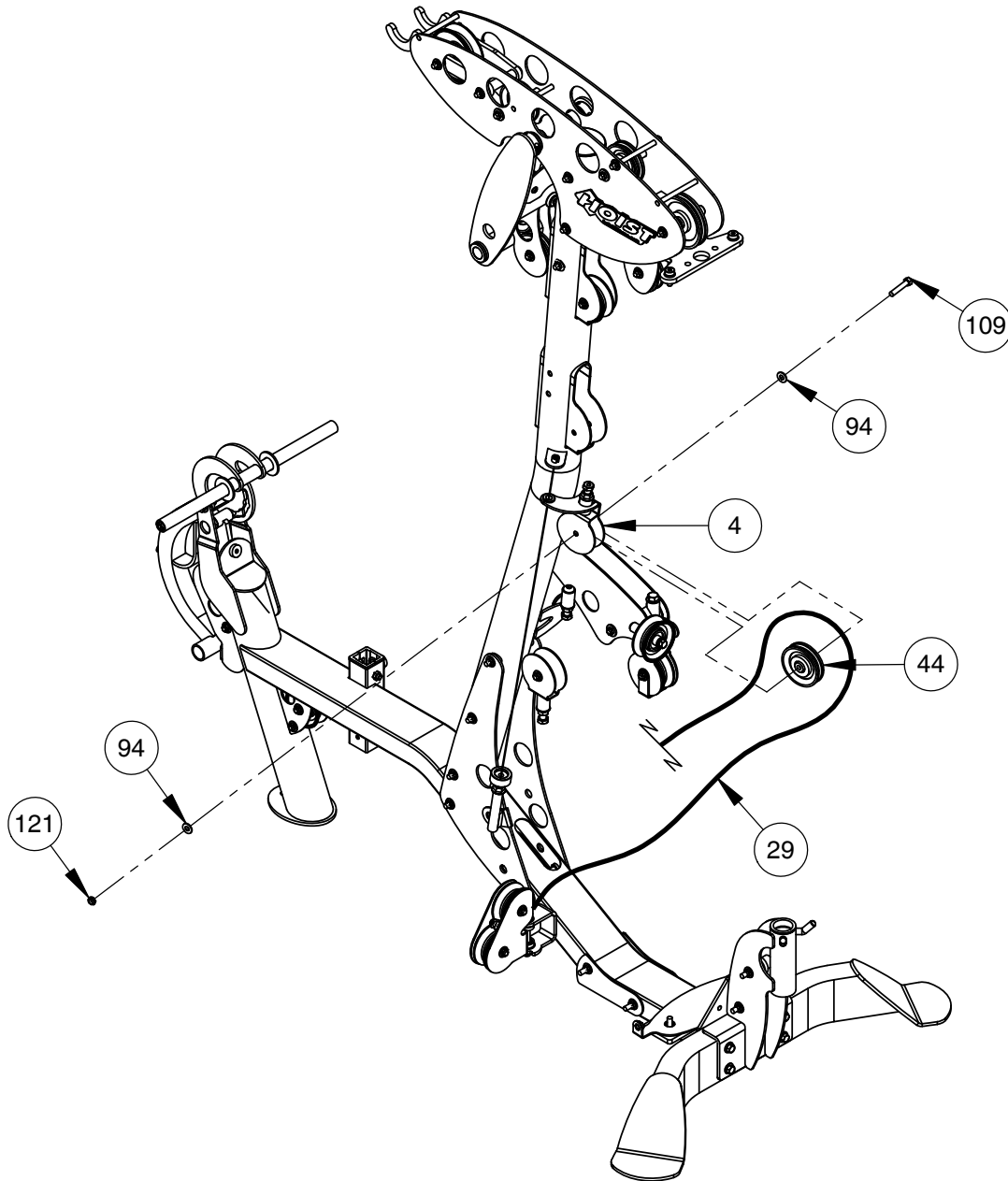

OWNER'S MANUAL

FRAME ASSEMBLY

NOTE:

- SOME PARTS MAY HAVE BEEN REMOVED FOR CLARITY.
- INSTALL **CABLE** AND PULLEYS AT THE SAME TIME.
- WRENCH TIGHTEN HARDWARE.

PROPERLY INSTALLED VIEW

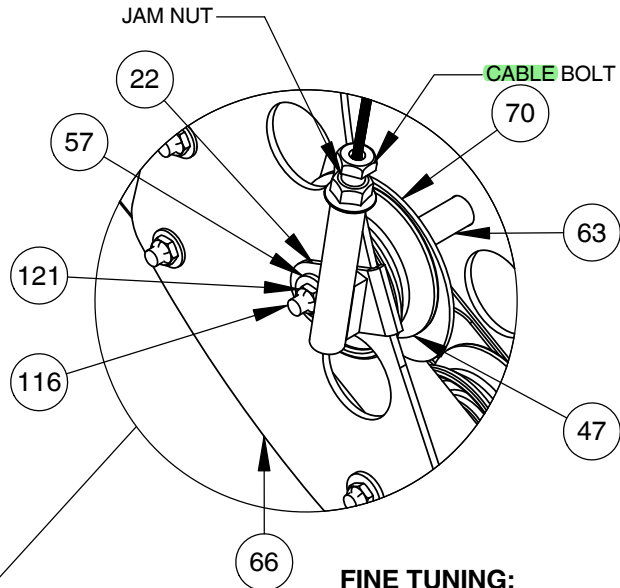

FINE TUNING:

LOOSEN JAM NUT AND THREAD BOLT IN/OUT TO GIVE THE **CABLE** PROPER TENSION. RE-TIGHTEN JAM NUT.

WARNING - CABLE BOLT MUST BE THREADED A MINIMUM OF 3/8" WITH JAM NUT TIGHTENED SECURELY TO ENSURE PROPER CONNECTION.

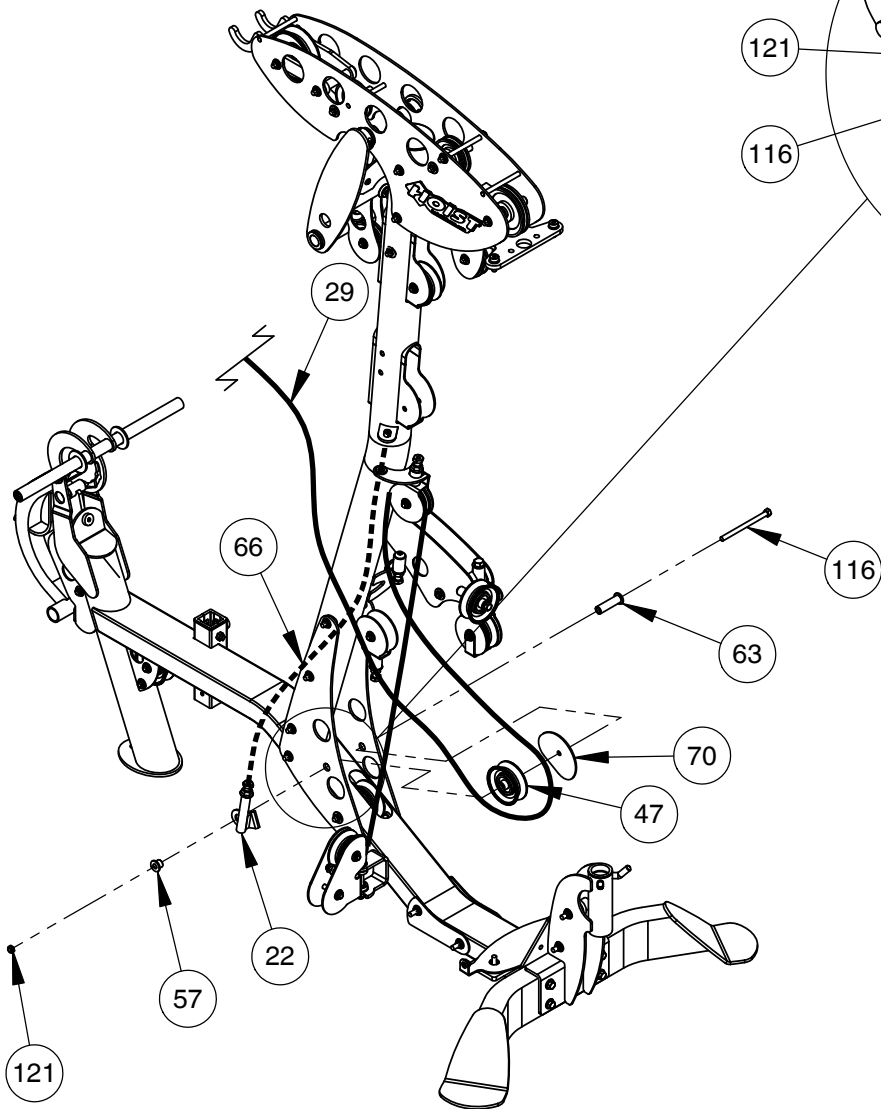

OWNER'S MANUAL

FRAME ASSEMBLY

NOTE:

- SOME PARTS MAY HAVE BEEN REMOVED FOR CLARITY.
- INSTALL **CABLE** AND PULLEYS AT THE SAME TIME.
- WRENCH TIGHTEN HARDWARE.

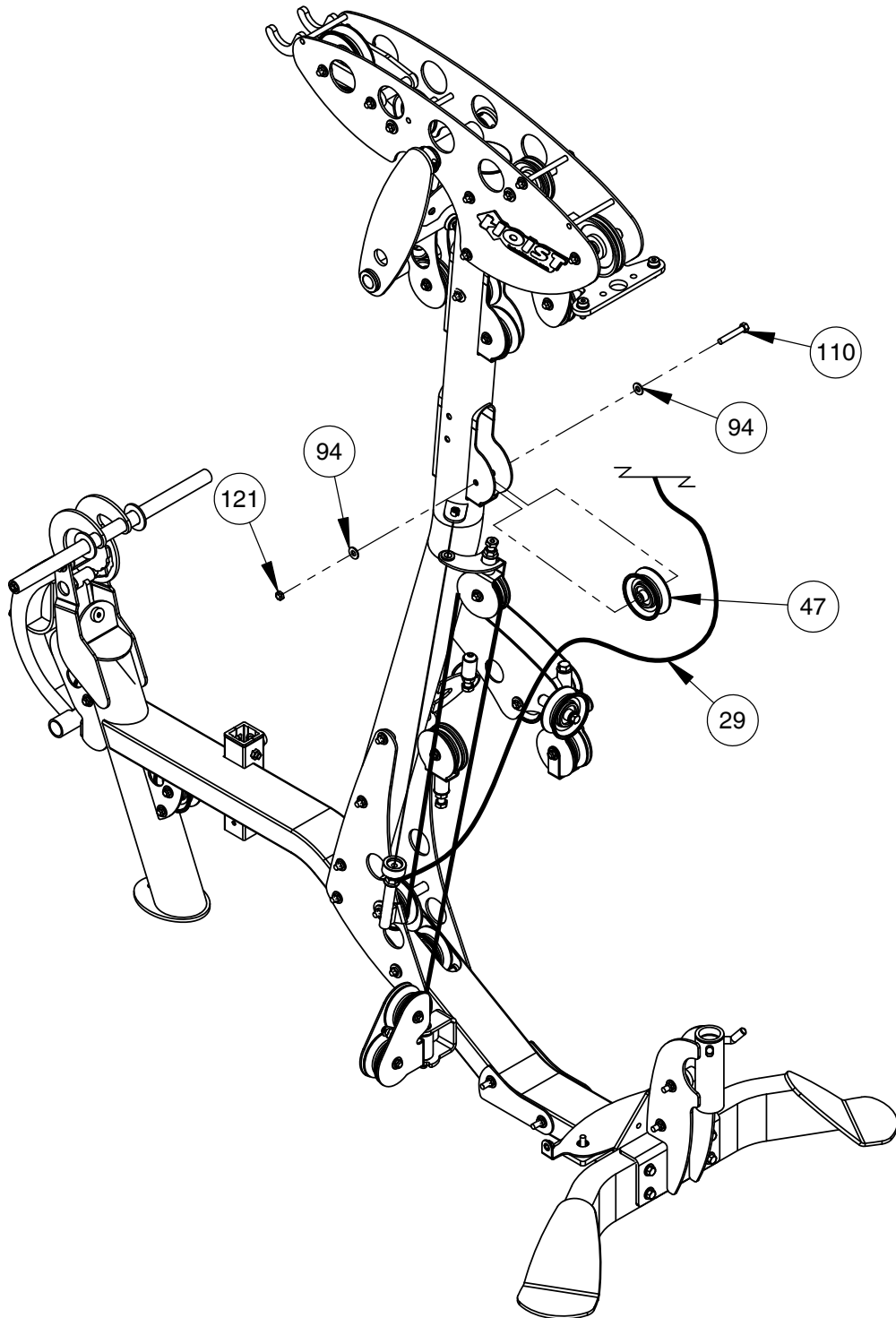

OWNER'S MANUAL

FRAME ASSEMBLY

PROPERLY INSTALLED VIEW

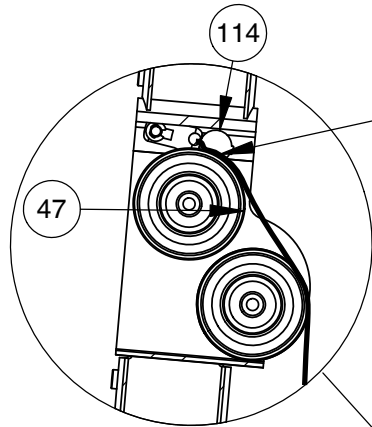

BE SURE TO POSITION
CABLE (29) BETWEEN
PULLEY (47) AND
CABLE GUARD BOLT (114)
AS SHOWN

NOTE:

- SOME PARTS MAY HAVE BEEN REMOVED FOR CLARITY.
- INSTALL CABLE AND PULLEYS AT THE SAME TIME.
- WRENCH TIGHTEN HARDWARE.

CABLE GUARD BOLT

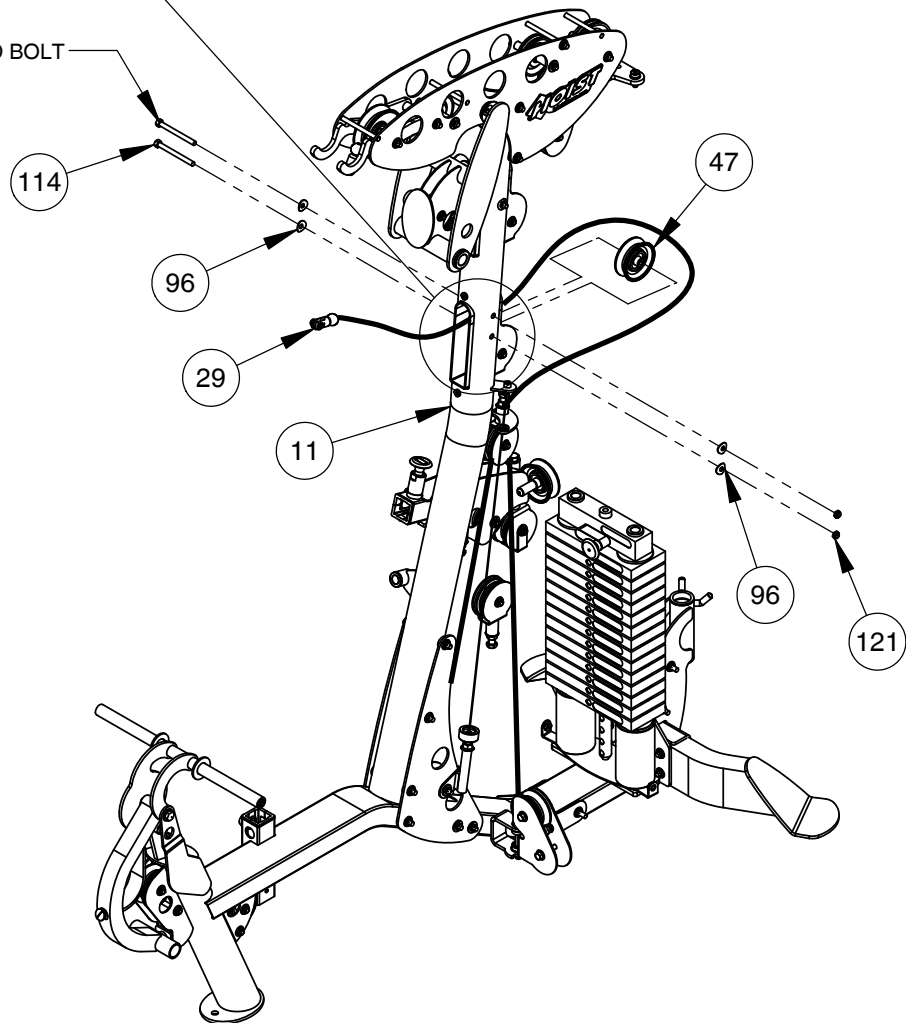

OWNER'S MANUAL

FRAME ASSEMBLY

- NOTE:
- WRENCH TIGHTEN HARDWARE.
- SOME PARTS MAY HAVE BEEN
REMOVED FOR CLARITY.

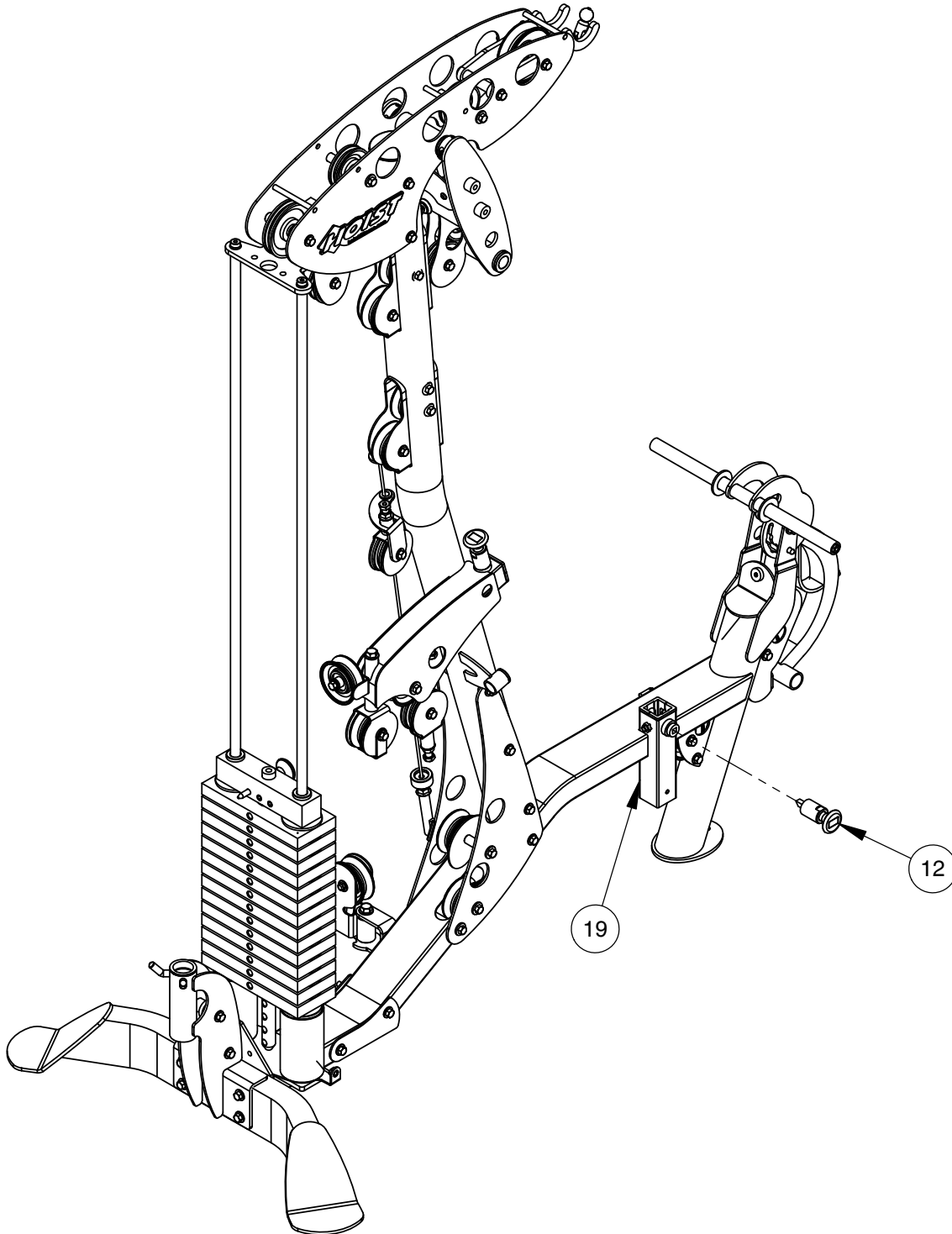

OWNER'S MANUAL

FRAME ASSEMBLY

- NOTE:
- WRENCH TIGHTEN HARDWARE.
- SOME PARTS MAY HAVE BEEN
REMOVED FOR CLARITY.

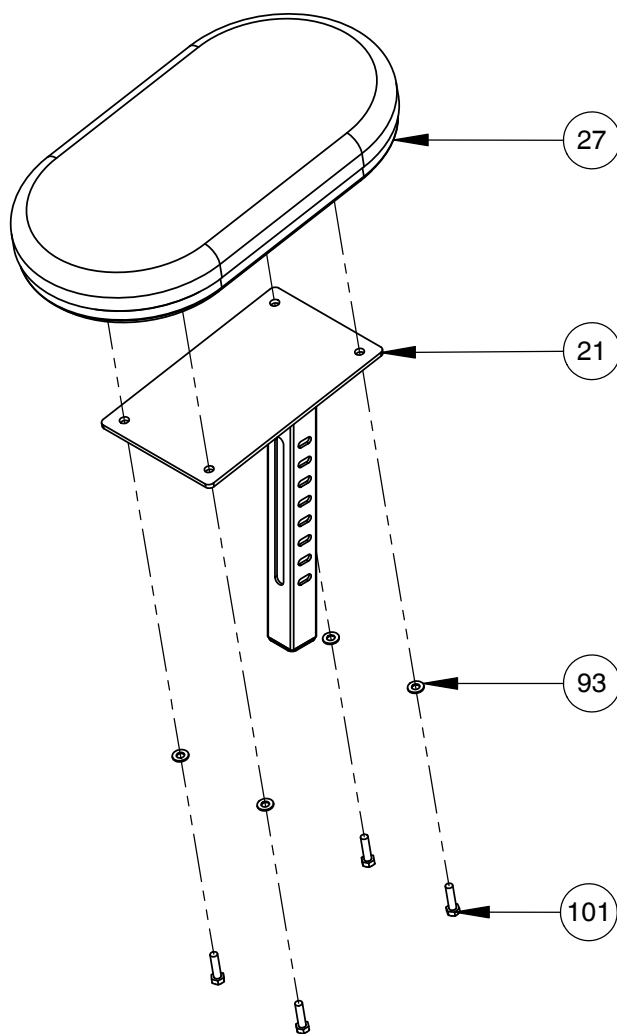

OWNER'S MANUAL

FRAME ASSEMBLY

NOTE:
- WRENCH TIGHTEN HARDWARE.
- SOME PARTS MAY HAVE BEEN
REMOVED FOR CLARITY.

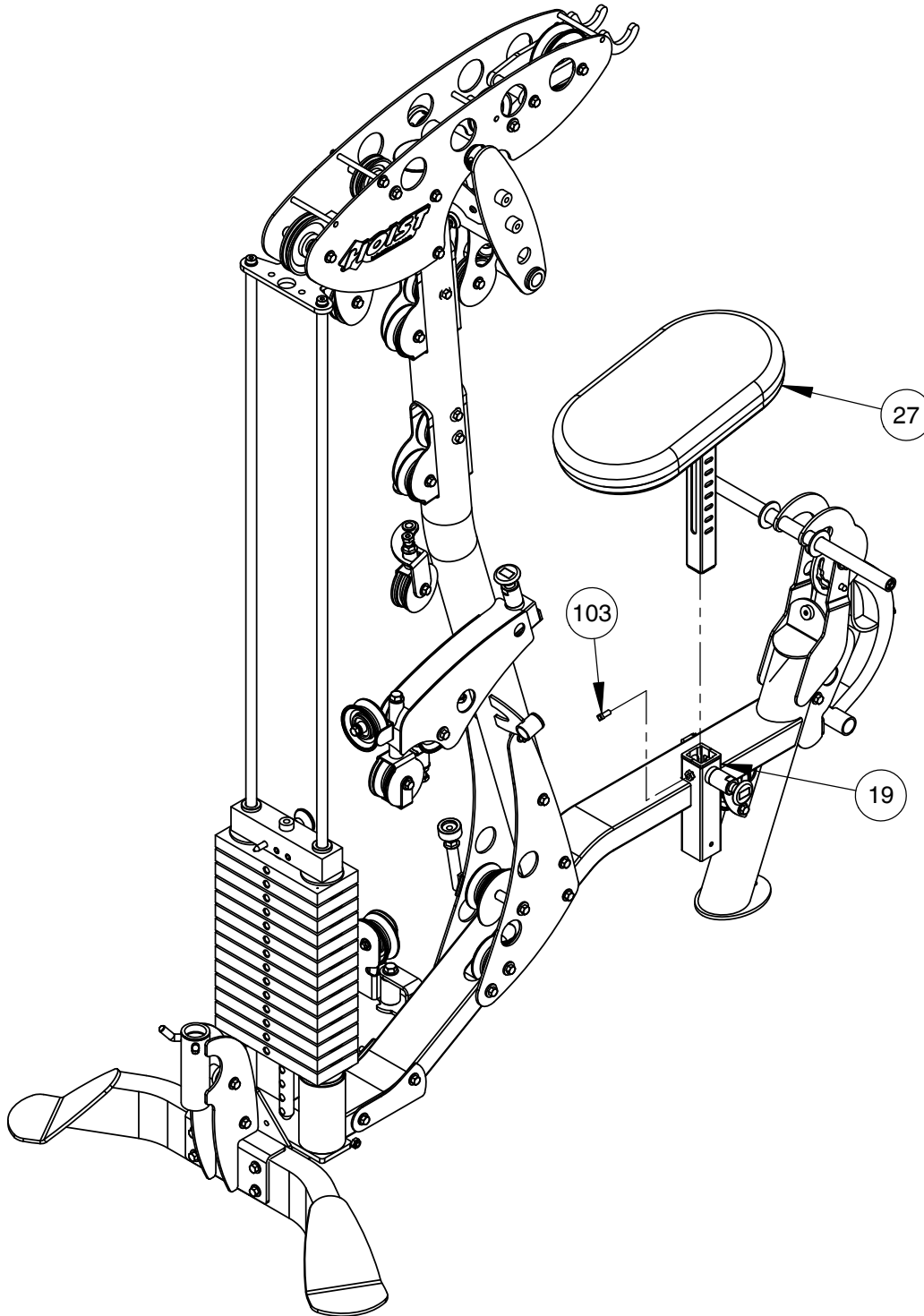

OWNER'S MANUAL

FRAME ASSEMBLY

- NOTE:
- WRENCH TIGHTEN HARDWARE.
- SOME PARTS MAY HAVE BEEN
REMOVED FOR CLARITY.

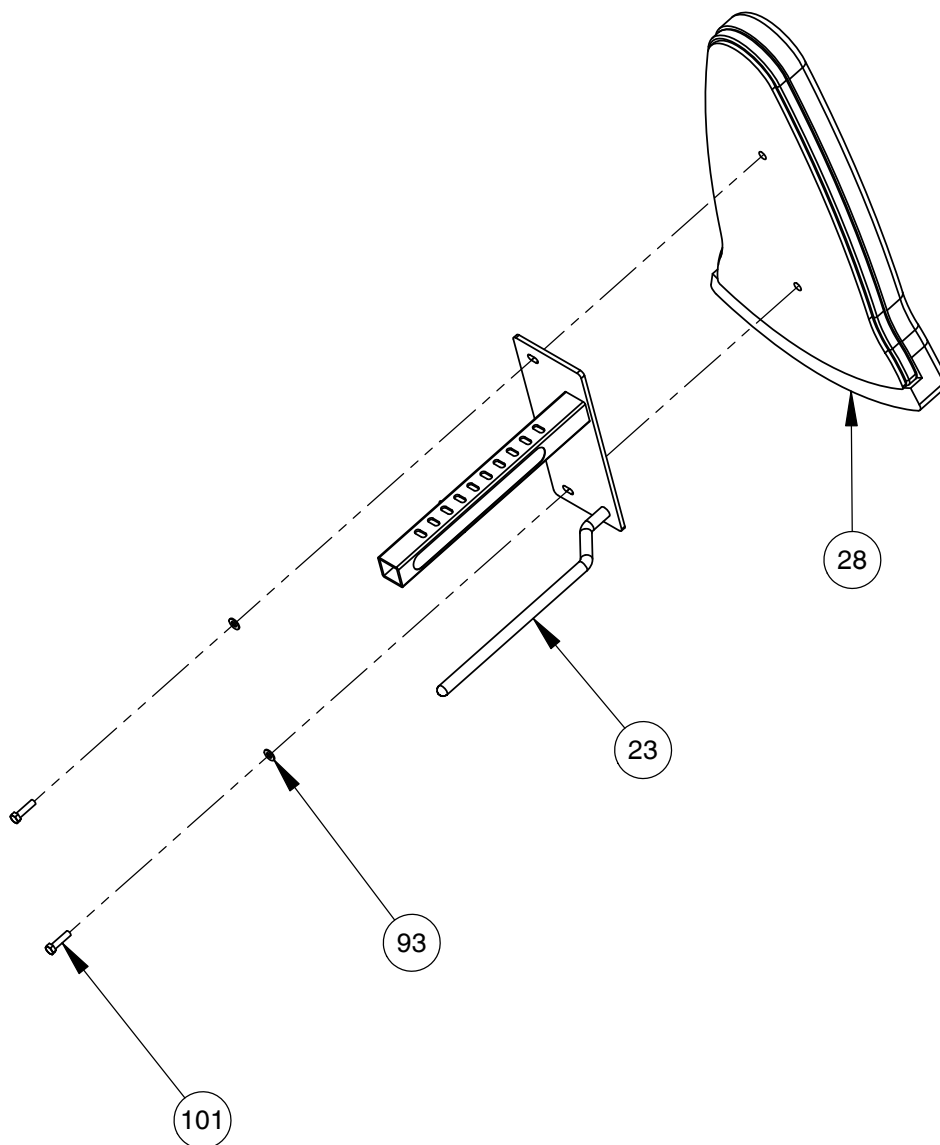

OWNER'S MANUAL

FRAME ASSEMBLY

NOTE:
- WRENCH TIGHTEN HARDWARE.
- SOME PARTS MAY HAVE BEEN
REMOVED FOR CLARITY.

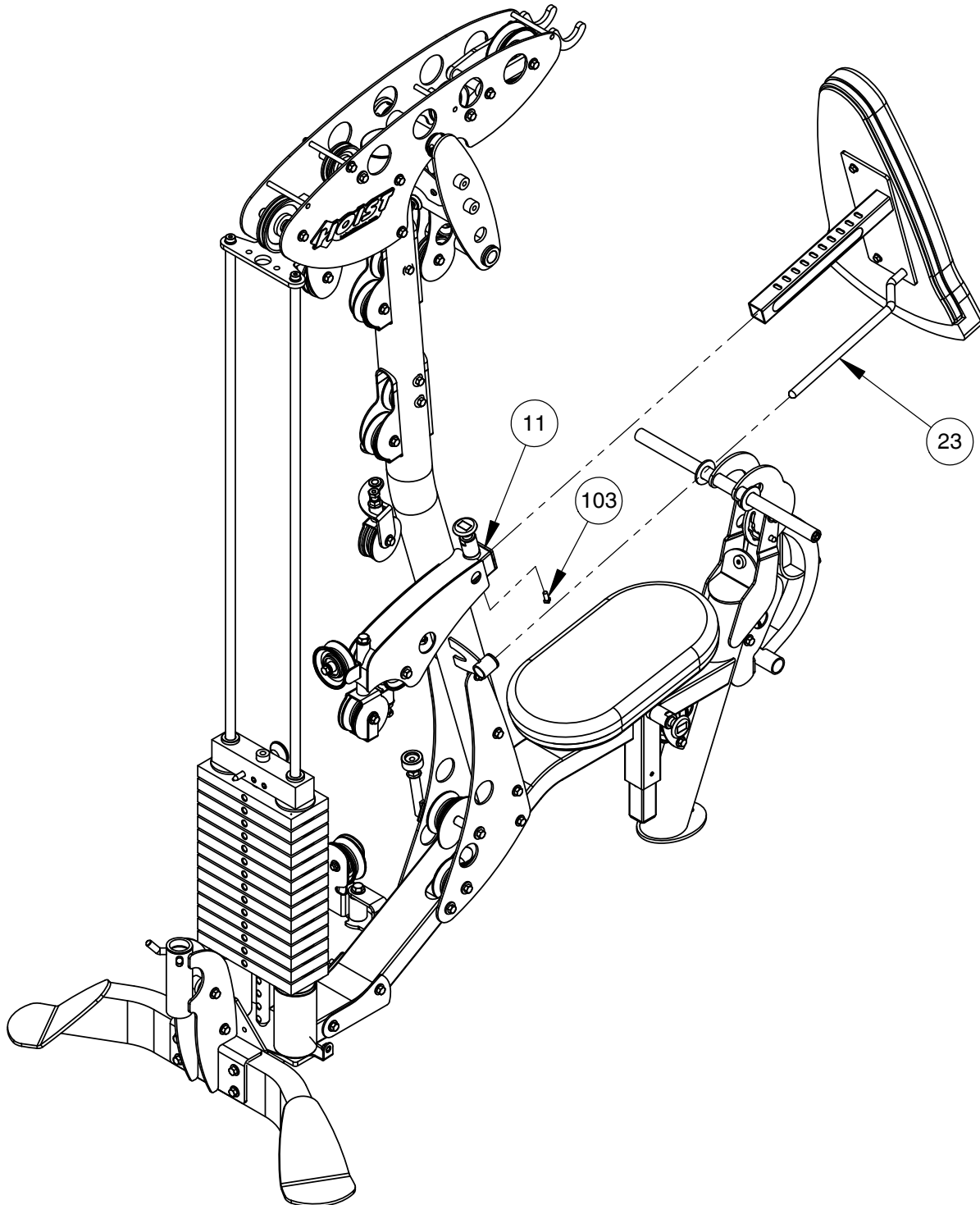

OWNER'S MANUAL

FRAME ASSEMBLY

NOTE:

- WRENCH TIGHTEN HARDWARE.
- WRENCH TIGHTEN ALL HARDWARE FROM PREVIOUS STEPS.
- REPEAT ASSEMBLY FOR OPPOSITE SIDE.
- SOME PARTS MAY HAVE BEEN REMOVED FOR CLARITY.

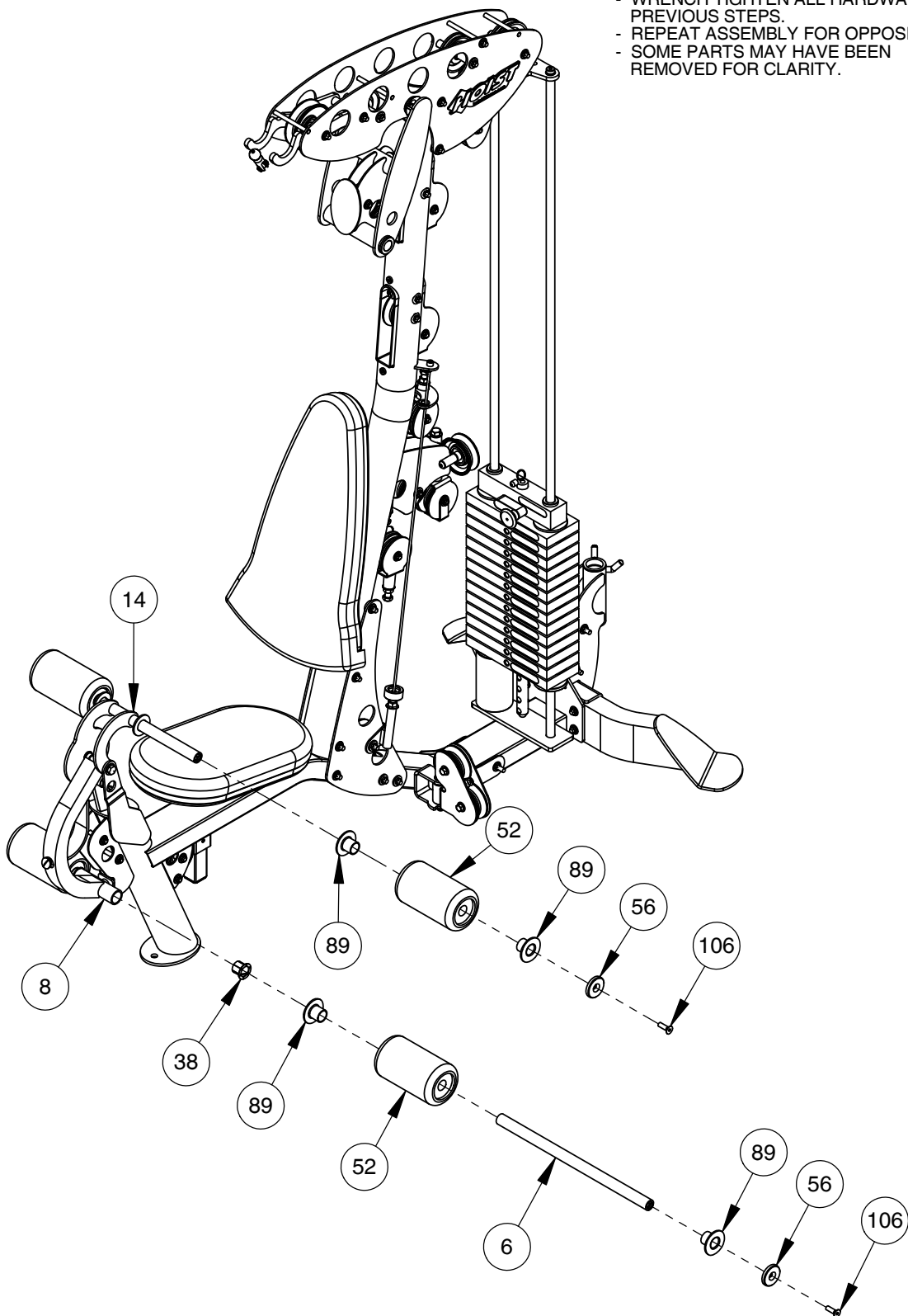

OWNER'S MANUAL

FRAME ASSEMBLY

- NOTE:
- SOME PARTS MAY HAVE BEEN
REMOVED FOR CLARITY.
- HAND TIGHTEN HARDWARE.
- REPEAT ASSEMBLY FOR OPPOSITE SIDE.

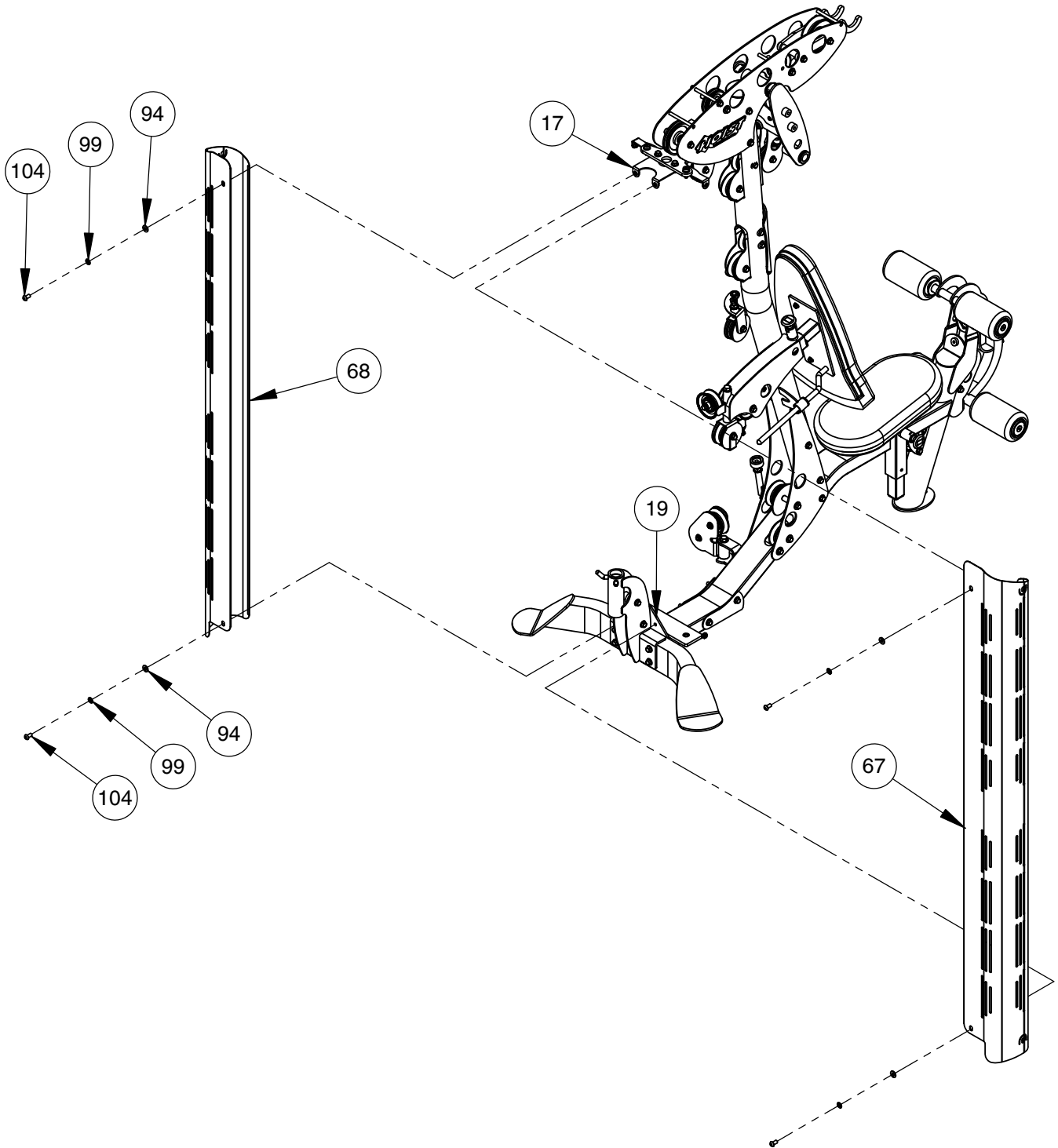

OWNER'S MANUAL

FRAME ASSEMBLY

NOTE:

- WRENCH TIGHTEN HARDWARE.
- WRENCH TIGHTEN ALL SHIELD HARDWARE FROM PREVIOUS STEPS.
- REPEAT ASSEMBLY FOR OPPOSITE SIDE.
- SOME PARTS MAY HAVE BEEN REMOVED FOR CLARITY.

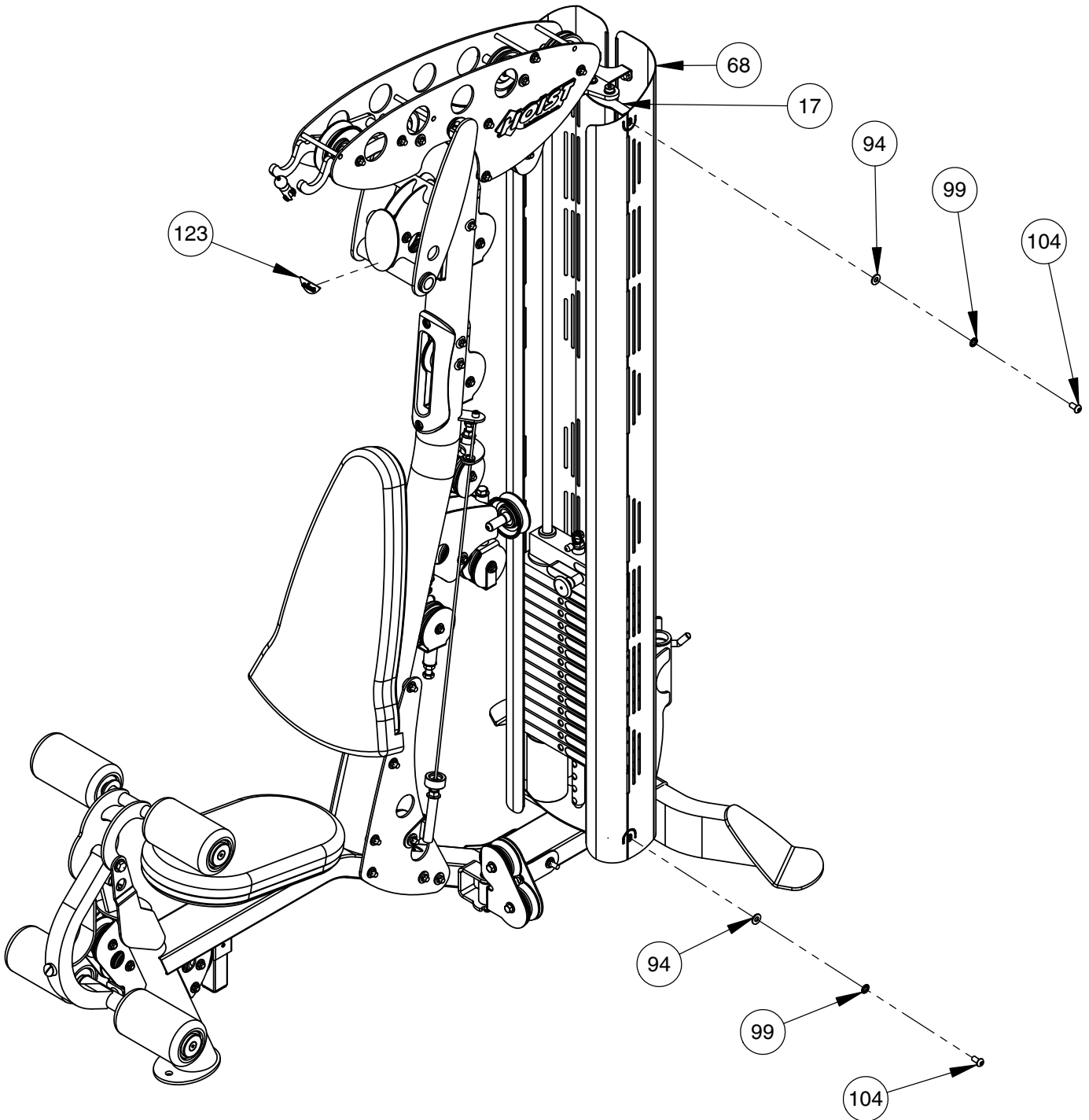

OWNER'S MANUAL

ACCESSORIES/MISC

NOTE:
- SOME PARTS MAY HAVE BEEN
REMOVED FOR CLARITY.

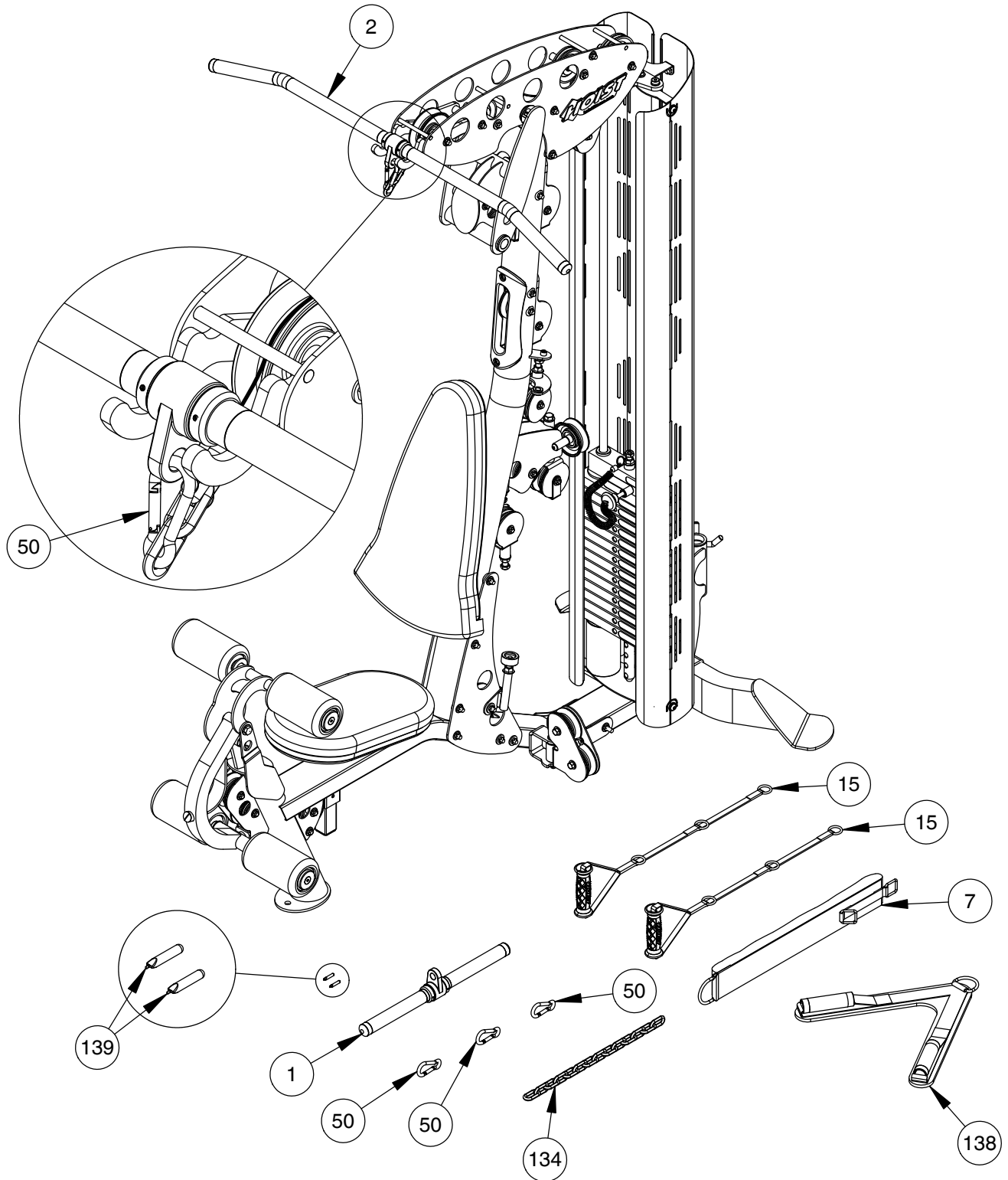

OWNER'S MANUAL

PRE-ASSEMBLY

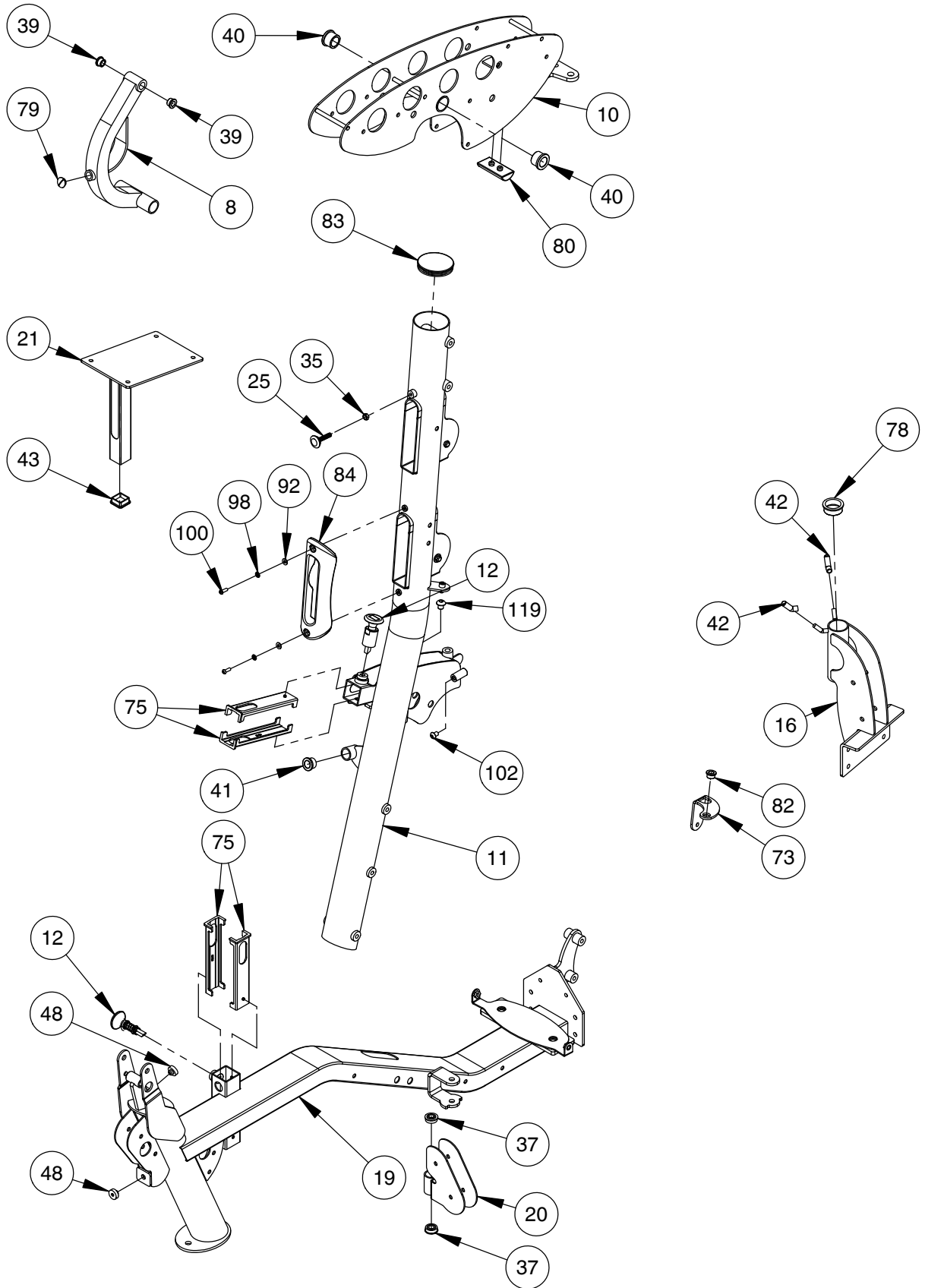

OWNER'S MANUAL

DECAL PLACEMENT

NOTE:

- ALL DECALS ARE CENTERED UNLESS OTHERWISE STATED.
- SOME PARTS MAY HAVE BEEN REMOVED FOR CLARITY.

* IF USING THE STANDARD 150LB. WEIGHT STACK, SET ASIDE WEIGHT STACK NUMBER DECALS 16-20. THESE ARE USED IN THE OPTIONAL 200 LB WEIGHT STACK.

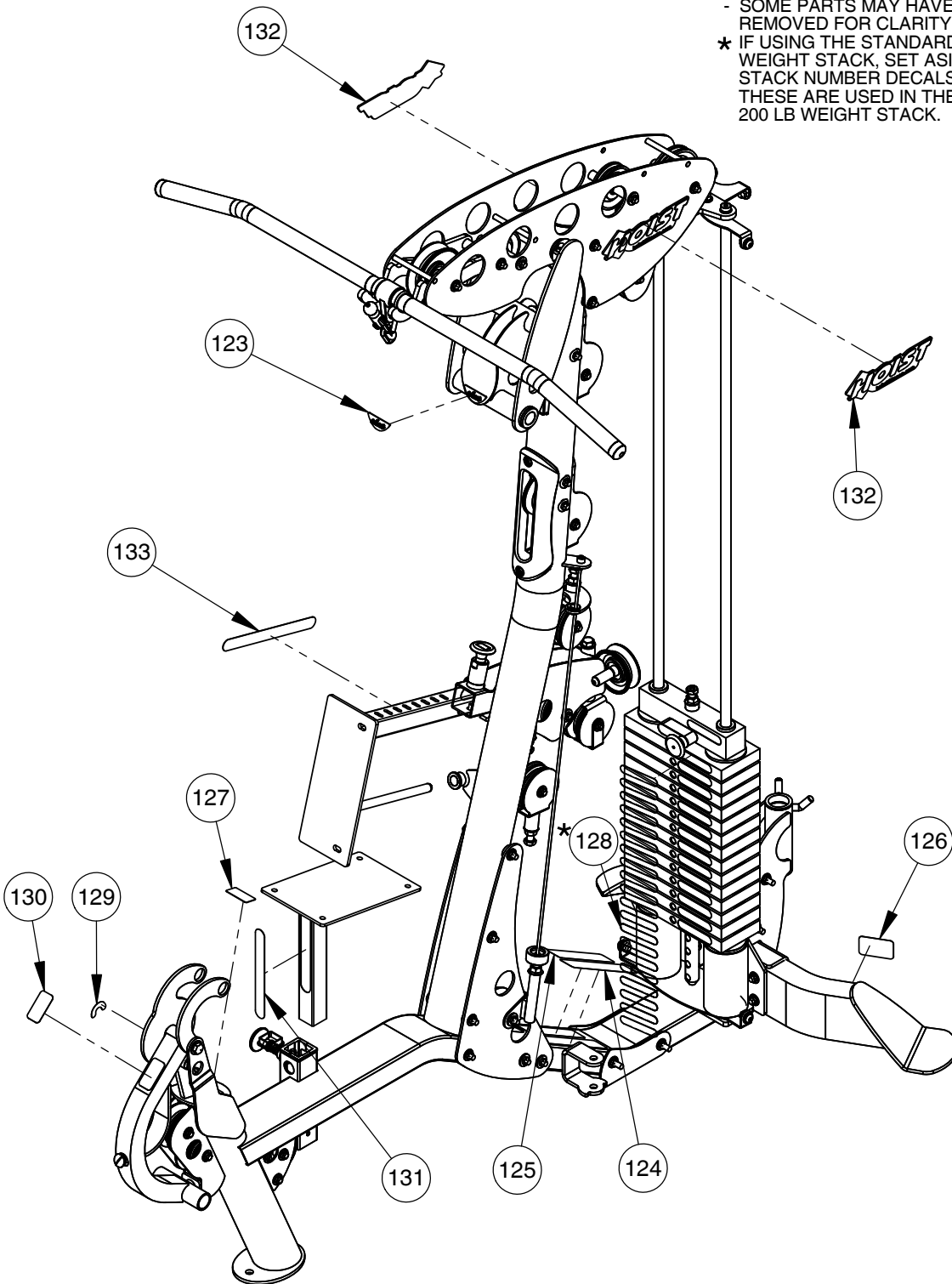

OWNER'S MANUAL

DECAL REFERENCE



021-0003673



021-0003341



1-800-548-5438
www.hoistfitness.com
SERIAL # 00-00-A-000000



SERIAL # DECAL

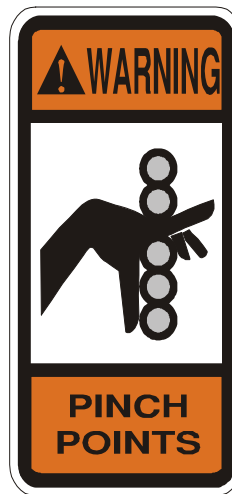

021-0003322



021-0003232



021-0018022



021-0003675

OWNER'S MANUAL

DECAL REFERENCE CONTINUED

10 LBS / 5 KGS	90 LBS / 41 KGS	170 LBS / 77 KGS
20 LBS / 9 KGS	100 LBS / 45 KGS	180 LBS / 82 KGS
30 LBS / 14 KGS	110 LBS / 50 KGS	190 LBS / 86 KGS
40 LBS / 18 KGS	120 LBS / 54 KGS	200 LBS / 91 KGS
50 LBS / 23 KGS	130 LBS / 59 KGS	
60 LBS / 27 KGS	140 LBS / 64 KGS	
70 LBS / 32 KGS	150 LBS / 68 KGS	
80 LBS / 36 KGS	160 LBS / 73 KGS	

021-0003965



021-0004101

NOTICE	COMMERCIAL MAINTENANCE	Daily	Weekly	Monthly	Yearly
		Inspect: Links, Pull Pins, Snap Locks, Swivels, Weight Stack Pins	X		
Clean; Upholstery	X				
Inspect: Cables or Belts and their tension	X				
Inspect: Accessory Bars and Handles		X			
Inspect: All Decals		X			
Inspect: All nuts and Bolts Tighten if Needed.		X			
Inspect: Anti-Skid Surfaces		X			
Clean & Lubricate; Guide Rods with a Teflon (PTFE) based lubricant (Superlube)			X		
Lubricate: Seat Sleeves, Turcite Bushings, Linear Bearing			X		
Clean & Wax; All Glossy Finishes				X	
Repack with Grease Linear Bearings				X	
Replace; Cables, Belts and Connecting Parts.				X	

021-0003008

WARNING
USE ONLY GENUINE HORST REPLACEMENT PARTS. FAILURE TO DO SO WILL VOID WARRANTY AND COULD RESULT IN PERSONAL INJURY OR EVEN DEATH. THERE IS A RISK ASSUMED BY INDIVIDUALS WHO USE THIS TYPE OF EQUIPMENT. TO MINIMIZE THE RISK, ALWAYS FOLLOW THESE SIMPLE RULES.

1. READ AND UNDERSTAND ALL ENCLOSED INSTRUCTIONS before using this equipment.
2. INSPECT EQUIPMENT BEFORE EACH USE. Replace all parts at the first signs of wear or damage. If in doubt about a certain part, DO NOT use the equipment until the part is replaced. Failure to replace worn or damaged parts may result in injury.
3. FOLLOW ROUTINE MAINTENANCE SCHEDULE. Refer to the owner's manual/maintenance decal.
4. CONSULT YOUR PHYSICIAN BEFORE STARTING ANY EXERCISE PROGRAM. Warm up properly before engaging in weight resistance training. Stop exercising if you feel faint, dizzy or pain.
5. TO PREVENT THE POSSIBILITY OF SERIOUS INJURY, KEEP CLEAR OF ALL MOVING PARTS. Do not attempt to free any jammed parts by yourself. Obtain assistance to avoid possible injury.
6. CHILDREN SHOULD NOT BE ALLOWED TO USE THIS EQUIPMENT WITHOUT ADULT SUPERVISION. To avoid possible injury, bystanders should be kept at a safe distance when this equipment is in use.
7. CALL YOUR AUTHORIZED DISTRIBUTOR if you have any questions on the proper use or maintenance of this equipment.
8. TO PREVENT POSSIBLE TIPPING, bolt this unit to the exercise floor. Failure to do so may result in serious injury or death.

021-0003135

OWNER'S MANUAL

THIS PAGE WAS INTENTIONALLY LEFT BLANK

OWNER'S MANUAL

PART LIST

NOTE: SOME OF THESE PARTS MAY COME PRE-INSTALLED

ITEM NO.	PART NUMBER	DESCRIPTION	QTY
1	026-01X1118	ALUMINUM CURL BAR ASSEMBLY	1
2	026-01X1119	ALUMINUM LAT BAR ASSEMBLY	1
3	026-01X1404	BAR MOUNT ASSEMBLY	1
4	026-01X1414	ADJ. FLOATING PULLEY HOUSING ASSEMBLY	2
5	026-01X1419	FRAME BASE ASSEMBLY	1
6	026-01X1425	ROLLER MOUNT ASSEMBLY	1
7	026-01X6020	FLEECE KNEE STRAP WITH (1) D-RING & 2 SQ. RINGS ASSEMBLY	1
8	026-01X2028	LEG EXTENSION ARM ASSEMBLY	1
10	026-01X7239	TOP MAIN FRAME ASSEMBLY	1
11	026-01X5163	MAIN UPRIGHT ASSEMBLY	1
12	026-01X3160	RATCHET PULL-PIN ASSEMBLY	2
13	026-01X3177	WIDE ADJ. FLOATING PULLEY HOUSING ASSEMBLY	1
14	026-01X4052	ROLLER MOUNT W/ ROM ASSEMBLY	1
15	026-01X5760	STRAP HANDLE WITH (3) O-RINGS (LOWER) ASSEMBLY	2
16	026-01X5007	ACCESSORY RACK ASSEMBLY	1
17	026-01X7241	SHIELD MOUNT - TOP ASSEMBLY	1
19	026-01X7238	SEAT FRAME ASSEMBLY	1
20	026-01X5079	SWIVEL PULLEY ASSEMBLY	1
21	026-01X5080	SEAT PAD ASSEMBLY	1
22	026-01X7122	ANTI-TWIST CABLE ANCHOR	1
23	026-01X5096	BACK PAD ADJUSTER ASSEMBLY	1
25	020-0014027	ADJUSTABLE STOP	1
27	022-01PD2301-A	SEAT PAD ASSEMBLY	1
28	022-01PD2304-A	PAD ASSEMBLY	1
29	010-01C0372	CABLE ASSEMBLY: V BASE AB 129.06" LG.	1
30	010-01C0373	CABLE ASSEMBLY: V BASE FLOATING PULLEY 94.25" LG.	1
31	010-01C0374	CABLE ASSEMBLY: V BASE PULL DOWN 143.13" LG.	1
32	010-01C0375	CABLE ASSEMBLY: V SELECT BASE LEG EXTENSION 63.66" LG.	1
34	011-0112002	1/2" X .500" SHSS (WZ)	2
35	012-0305003	3/8"-16UNC JAM NUT (WZ)	1
36	013-0102006	1/2" FLAT NYLON WASHER	2
37	014-0003003	BEARING: FLANGED BALL BEARING ϕ .50" I.D.	2
38	014-0011001	NYLINER BUSHING: ϕ 1.09" O.D. X ϕ 1.00" I.D X 1.13" LG.	2
39	014-0101002	BUSHING: OILITE FLANGED ϕ .75" O.D X ϕ .50" I.D X .38" LG.	2

OWNER'S MANUAL

PART LIST CONTINUED

NOTE: SOME OF THESE PARTS MAY COME PRE-INSTALLED

ITEM NO.	PART NUMBER	DESCRIPTION	QTY
40	014-0101005	BUSHING: OILITE FLANGED Ø1.38" O.D. X Ø1.00" I.D. X .81" LG.	2
41	014-0101014	FLANGED OILITE 0.75" I.D. X .60" L.G.	1
42	016-0002007	VINYL SLEEVE Ø.38" X 1.63"	2
43	016-0201004	END CAP 1.50" X 1.50" (BLACK)	1
44	018-0001002	CABLE PULLEY: Ø3.50"	8
45	018-0001003	CABLE PULLEY: Ø4.50"	1
46	018-0002014	CABLE PULLEY: WIDE (BORED HUB) Ø4.50"	1
47	018-0002015	CABLE PULLEY: WIDE (BORED HUB) Ø 3.50"	14
48	019-0001001	PLUG BUMPER	2
49	019-0001006	THICK RUBBER DONUT Ø3.00" X .50" BLACK	2
50	020-0010002	SNAP LINK	4
51	020-0011009	SPRING	1
52	022-01PDR008	ROLLER PAD Ø4.00" X 7.00" LG.	4
53	026-01G0177	GUIDE ROD Ø.75" X 71.44" LG.	2
54	026-01M0128-1	PULL PIN CAP	1
55	026-01M0200	QUICK RELEASE CABLE LOCK Ø.34" I.D. X 1.00"LG.	2
56	026-01M0238	FLATHEAD CAP Ø2.00" ALUM.	4
57	026-01M0760	HEAVY FLANGED SPACER: Ø.67 O.D. X Ø.39 I.D. X .50 LG.	4
58	026-01M0761	HEAVY FLANGED SPACER: Ø.39" I.D X 1.69" LG.	4
59	026-01M0849	PUSH PIN PLUNGER Ø.61 CRS X 3.19" LG.	1
60	026-01M0863	HEAVY FLANGED SPACER: Ø .39" I.D. X .38" LG.	2
62	026-01M2268	SHAFT: Ø 1.00 X 6.56" LG.	1
63	026-01M2539	HEAVY FLANGED SPACER Ø.39" I.D. X 2.36" LG.	2
64	026-01M2553	SPACER .75" O.D. X .39" I.D. X 1.50" LG.	2
65	026-01P1689	DOUBLE PULLEY MOUNT PLATE	2
66	026-01P3368	GUSSET PLATE	2
67	026-01P6594	SHIELD-2	1
68	026-01P6593	SHIELD-1	1
69	026-01P6119	BACKING PLATE	2
70	026-01P6073	PULLEY PLATE	1
71	026-01P6075	BRKT-U	1
73	026-01P6098	ANTI-TWIST BRKT	1
75	026-01PL0125	E-Z GLIDE PLASTIC SLEEVE	4
77	026-01PL0369	WEIGHT STAND OFF	2

OWNER'S MANUAL

PART LIST CONTINUED

NOTE: SOME OF THESE PARTS MAY COME PRE-INSTALLED

ITEM NO.	PART NUMBER	DESCRIPTION	QTY
78	026-01PL0371	DELTRIN BUSHING	1
79	026-01PL0380	BLACK NYLON THREADED CAP	1
80	026-01PL0381	BUMPER, HALF ROUND, DUAL STEM	1
81	026-01PL2201	PLASTIC SLEEVE ϕ .75" O.D.	2
82	026-01PL2245	PLASTIC FLANGED BUSHING ϕ .75" O.D X ϕ .50" I.D X .38" LG.	1
83	026-01PL2316	ENDCAP (DOMED) - GREY ϕ 1.00"	1
84	026-01PL2413	SLOT COVER	1
85	026-01PL2422	STOP DISK	1
89	26-STD-06-0481	ROLLER PAD BUSHING	8
90	WS#22	150 LBS. STACK (8.25 LBS. TOP PLATE W/ 20 HOLE STEM)	1
92	013-0002003	1/4" X 16mm SAE FLAT WASHER (WZ)	2
93	013-0302008	5/16" SAE FLAT WASHER (WZ)	6
94	013-0402007	3/8" X 22mm FLAT WASHER (WZ)	81
95	013-0102003	1/2" X 27mm SAE FLAT WASHER (WZ)	5
96	013-0102028	3/8" CURVED WASHER (WZ)	6
97	013-0102020	3/8" SPLIT LOCK WASHER (WZ)	2
98	013-0102023	1/4" INTERNAL LOCK WASHER (WZ)	2
99	013-0102022	3/8" INTERNAL LOCK WASHER (WZ)	9
100	011-0102008	1/4"-20UNC X.75" BHCS (WZ)	2
101	011-0107011	5/16"-18UNC X 1.25" HHB (WZ)	6
102	011-0101107	3/8"-16UNC X .50" BHCS (WZ)	1
103	011-0311013	3/8"-16UNC X .75" SQUARE HEAD (WZ)	2
104	011-0101041	3/8"-16UNC X .75" BHCS (WZ)	8
105	011-0107020	3/8"-16UNC X 3.25" HHB (WZ)	2
106	011-0002033	3/8"-16UNC X 1.25" FHCS (WZ)	4
107	011-0107037	3/8"-16UNC X 1.25" HHB (WZ)	4
108	011-0407027	3/8"-16UNC X 1.75" HHB (WZ)	5
109	011-0407058	3/8"-16UNC X 2.00" HHB (WZ)	1
110	011-0107026	3/8"-16UNC X 2.25" HHB (WZ)	9
111	011-0107009	3/8"-16UNC X 2.50" HHB (WZ)	1
112	011-0007050	3/8"-16UNC X 2.75" HHB (WZ)	1
113	011-0407026	3/8"-16UNC X 3.00" HHB (WZ)	4
114	011-0407025	3/8"-16UNC X 4.00" HHB (WZ)	3

OWNER'S MANUAL

PART LIST CONTINUED

NOTE: SOME OF THESE PARTS MAY COME PRE-INSTALLED

ITEM NO.	PART NUMBER	DESCRIPTION	QTY
115	011-0107022	3/8"-16UNC X 5.00" HHB (WZ)	14
116	011-0407070	3/8"-16UNC X 5.25" HHB (WZ)	3
117	011-0407000	1/2"-13UNC X 3.50" HHB (WZ)	1
118	011-0407047	1/2"-13UNC X 4.00" HHB (WZ)	1
119	011-0101085	1/2"-13UNC X .50" BHCS (WZ)	1
121	012-0104008	3/8"-16 UNC THIN NYLOCK NUT (WZ)	44
122	012-0304011	1/2"-13 UNC THIN NYLOCK NUT (WZ)	1
123	021-0003673	DECAL V-SELECT BADGE	1
124	021-0003135	DECAL WARNING 1.50" X 7.75"	1
125	021-0003008	DECAL COMMERCIAL MAINTENANCE 1.50 X 6.69	1
126	SERIAL # DECAL	DECAL HOIST SERIAL # 1.63" X 2.63"	1
127	021-0003341	DECAL PINCH POINT 1.07" X 2.13" (HORIZONTAL)	1
128	021-0003965	DECAL: WEIGHT STACK 22 (10-200 LBS.)	1
129	021-0003232	DECAL PUSH TO ADJUST	1
130	021-0003322	DECAL PINCH POINT 1.25" X 2.31" (VERTICAL)	1
131	021-0004101	DECAL ADJUST 1-8 VERTICAL	1
132	021-0018022	DECAL HOISTFITNESS.COM LOGO	2
133	021-0003675	DECAL V BACK ADJUSTER	1
134	020-0014028	14 LINK CHAIN	1
135	011-0107079	1/2"-13UNC X 3.78" (96mm) HHB (WZ) W/ NYLON PATCH	1
136	012-0105008	1/2"-13 ACORN NUT (WZ)	1
138	022-0008032	AB STRAP	1
139	002-0001013	1cc of Synthetic Multi-Purpose Grease (PTFE)	2
140	010-01C0666	ANTI-TWIST CABLE: 34.76" LG.	1
141	026-01PL2393	Ø3.00" X .81" ID X.313" T SPACER	2

OWNER'S MANUAL

THIS PAGE WAS INTENTIONALLY LEFT BLANK

OWNER'S MANUAL

ABBREVIATIONS

BZ = Black Zinc
Ni = Nickel Plated
SS = Stainless Steel
WZ = White Zinc

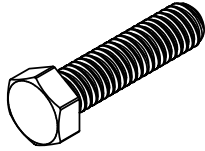

HHB = Hex Head Bolt

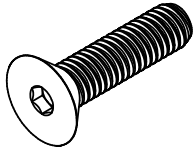

FHCS = Flat Head Cap Screw

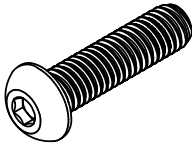

BHCS = Button Head Cap Screw

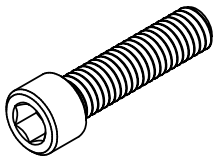

SHCS = Socket Head Cap Screw

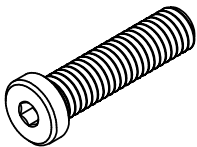

Low Head SHCS = Low Head Socket
Head Cap Screw

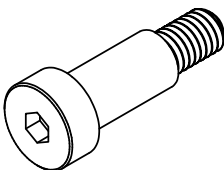

SHSS = Socket Head Shoulder Screw

OWNER'S MANUAL

BOLT SIZING CHART

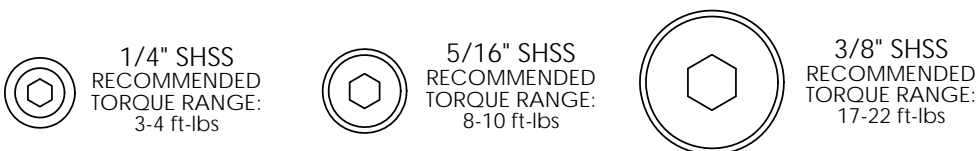
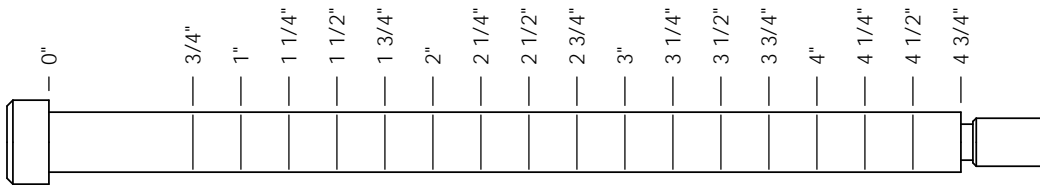
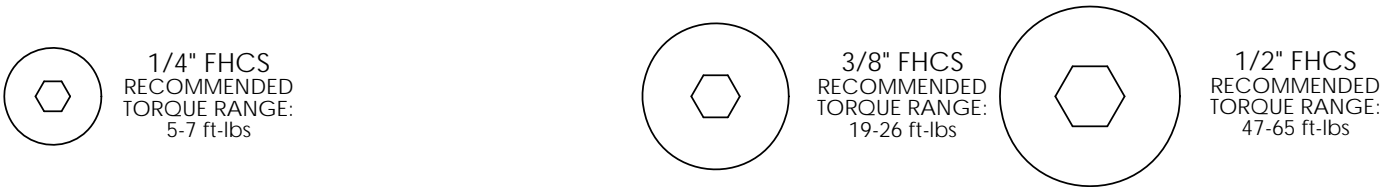
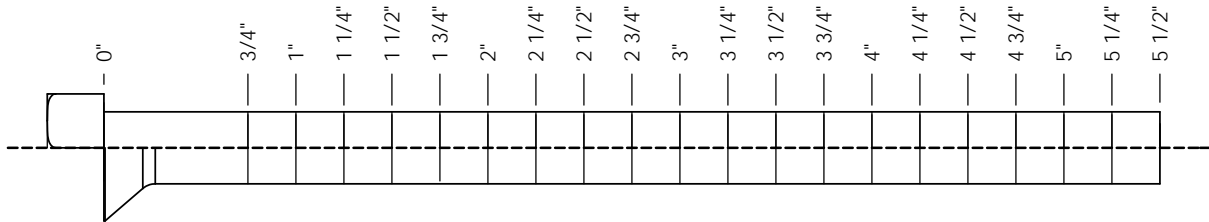
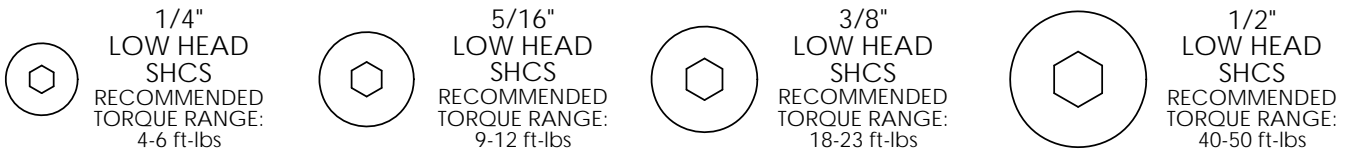
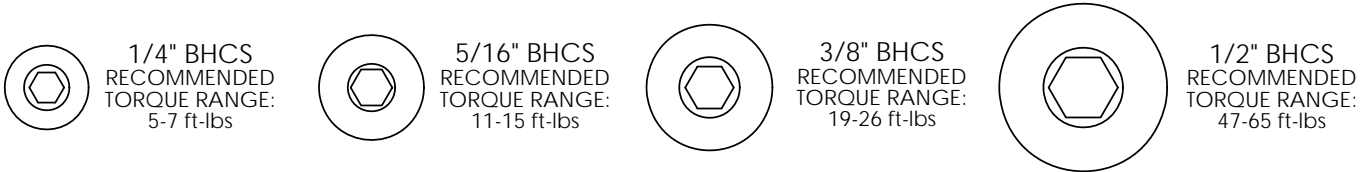
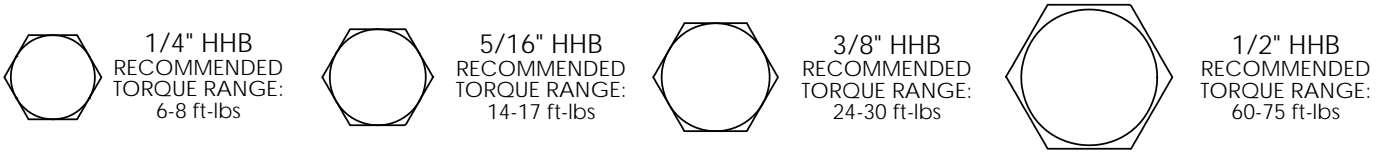

OWNER'S MANUAL

WASHER SIZING CHART

013-0002003
1/4"
FLAT WASHER
SMALL, SAE, 13mm

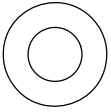

013-0102004
5/16"
FLAT WASHER
LARGE, USS, 22mm

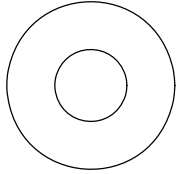

013-0002004
3/8"
FLAT WASHER
SMALL, SAE, 21mm

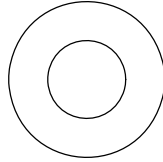

013-0402005
3/8"
FLAT WASHER
LARGE, USS, 25mm

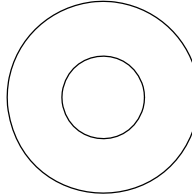

013-0102003
1/2"
FLAT WASHER
SMALL, SAE, 27mm

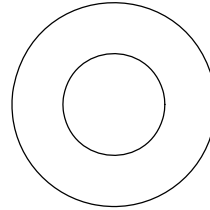

013-0102026
1/2"
FLAT WASHER
LARGE, USS, 34mm

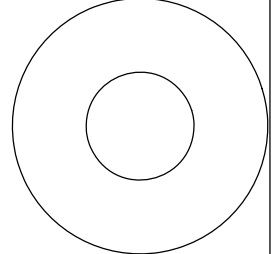

013-0102028
3/8"
CURVED WASHER

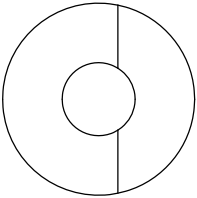

013-0402007
3/8"
FLAT WASHER
22mm O.D.

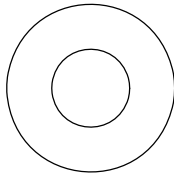

013-0102019
1/4"
LOCK WASHER



013-0102020
3/8"
LOCK WASHER

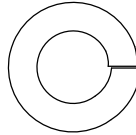

013-0102018
1/2"
LOCK WASHER

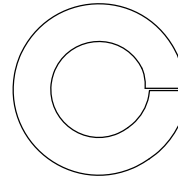

014-0018001
1/2" LONG
SPACER

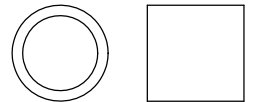

026-01M0238
2" ALUMINUM
FLATHEAD CAP

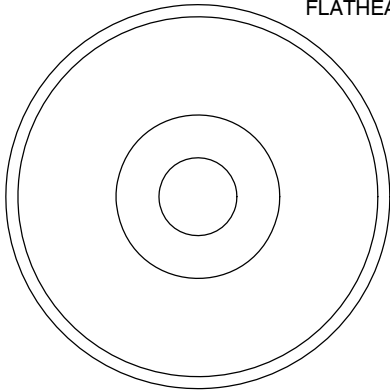

016-0009003
1" SHIM WASHER

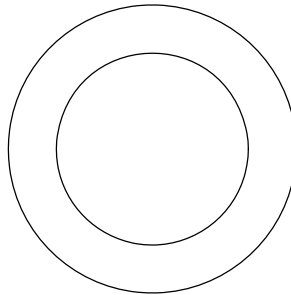

013-0003002
3/8" FENDER WASHER

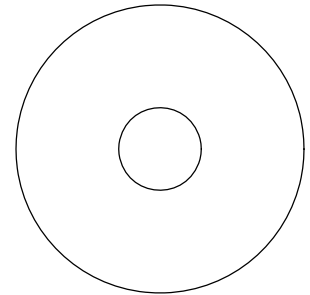

013-0003004
1 1/16"
FENDER WASHER

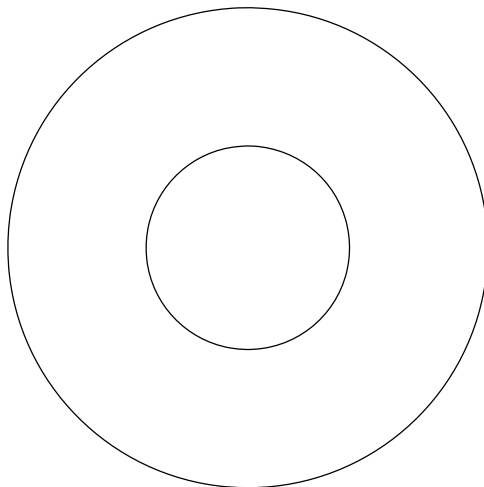

026-01PL151
PLASTIC 1 1/16"
FENDER WASHER

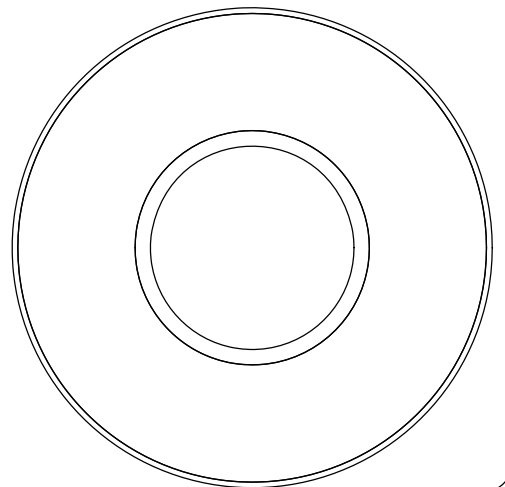

014-0018002
1" LONG
SPACER

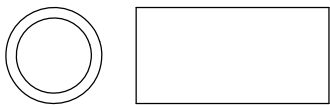

OWNER'S MANUAL

WASHER SIZING CHART (CONTINUED)

026-01M0211
1/4" LONG
FLANGED SPACER

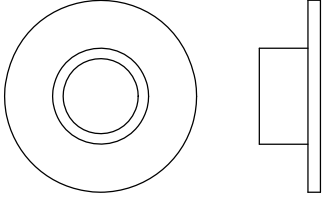

026-01M0198
1/2" LONG
FLANGED SPACER

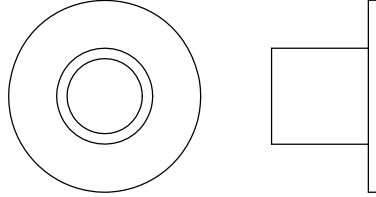

026-01M0760
1/2" LONG HEAVY
FLANGED SPACER

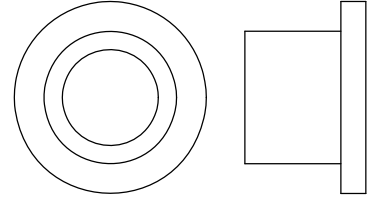

026-01M211T
1/4" LONG HEAVY
FLANGED SPACER

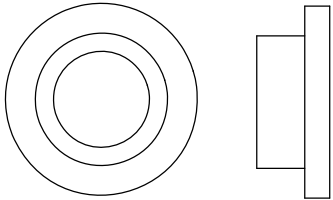

026-01M0532
11/16" LONG HEAVY
FLANGED SPACER

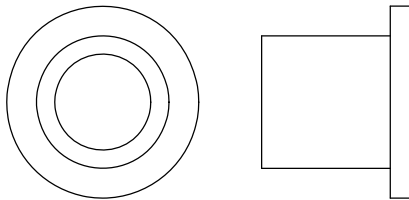

026-01M0551
1" LONG HEAVY
FLANGED SPACER

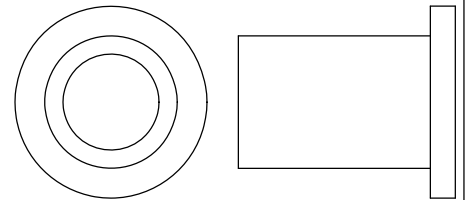

026-01M0788
.81" LONG HEAVY
FLANGED SPACER

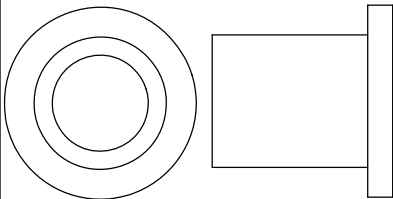

026-01M0780
.65" LONG HEAVY
FLANGED SPACER

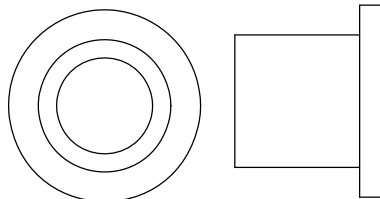

026-01M0761
1 11/16" LONG HEAVY
FLANGED SPACER

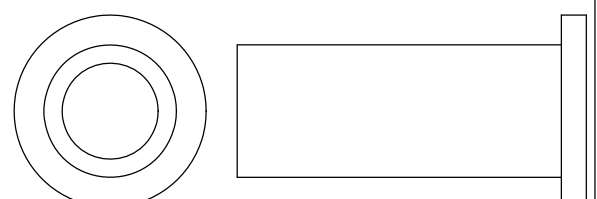

026-01M0789
.44" LONG HEAVY
FLANGED SPACER

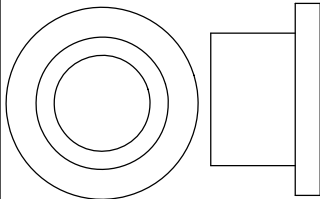

026-01M0762
1 1/2" LONG HEAVY
FLANGED SPACER

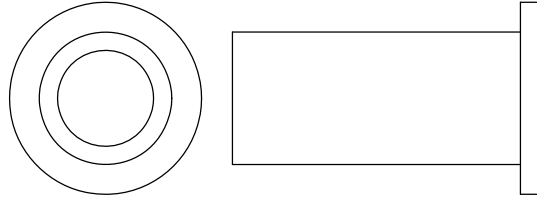

026-01M0768
1 1/4" LONG HEAVY
FLANGED SPACER

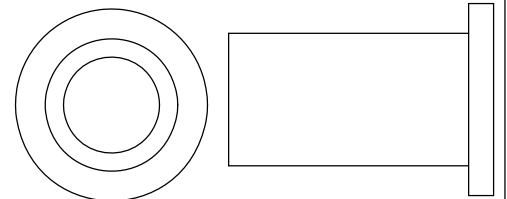

026-01M0600
.625" LONG
FLANGED SPACER

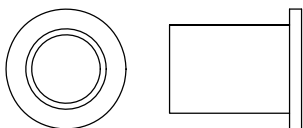

026-01M0240
1 3/8" ALUMINUM
FLATHEAD CAP

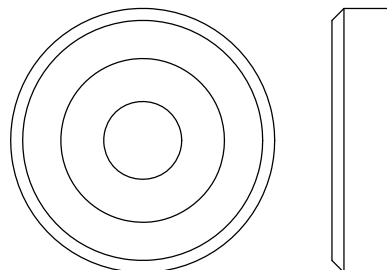

026-01M0239
1 5/8" ALUMINUM
FLATHEAD CAP

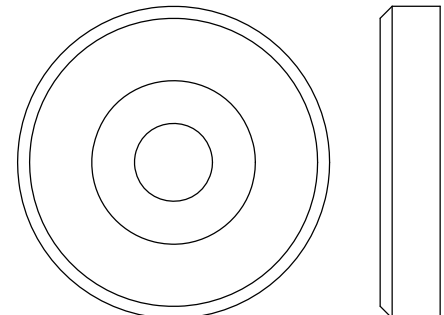

OWNER'S MANUAL

MAINTENANCE SCHEDULE

ROUTINE	COMMERCIAL / LIGHT COMMERCIAL MAINTENANCE	HOME MAINTENANCE	LATEST DATE ENTRY																	
Inspect; Links, Pull Pins, Snap Locks, Swivels, Weight Stack Pins	DAILY	WEEKLY																		
Clean; Upholstery	DAILY	WEEKLY																		
Inspect; Cables or Belts and their tension	DAILY	WEEKLY																		
Inspect; Accessory Bars, and Handles	WEEKLY	3 MONTHS																		
Inspect; All Decals	WEEKLY	3 MONTHS																		
Inspect; All Nuts and Bolts, Tighten if needed	WEEKLY	3 MONTHS																		
Inspect; Anti-Skid Surface	WEEKLY	3 MONTHS																		
Clean & Lubricate; Guide Rods with a Teflon (PTFE) based lubricant (Superlube)	MONTHLY	3 MONTHS																		
Lubricate; Seat Sleeves, Turcite Bushings, Linear Bearing	MONTHLY	3 MONTHS																		
Clean and Wax; All Glossy Finishes	6 MONTHS	YEARLY																		
Repack with Grease; Linear Bearings	6 MONTHS	YEARLY																		
Replace; Cables, Belts and Connecting Parts	YEARLY	3 YEARS																		

*Your equipment comes with a commercial maintenance decal.
For personal, in home use, please follow the home maintenance schedule listed above.*

Never use ammonia, acid-based, or petroleum-based solvents on any portion of the machine as it may damage the finish.

OWNER'S MANUAL

HOIST FITNESS SYSTEMS GENERAL MAINTENANCE INFORMATION

Links, Pull-Pins, Snap Hooks, Swivels, Weight Stack Pins:

- *Check all pieces for signs of visible wear or damage.
- *Check springs in snap hooks and pull-pins for proper tension and alignment.
- *If the spring sticks or has lost its rigidity, replace it immediately.

Upholstery:

- *To ensure prolonged upholstery life and proper hygiene, all upholstered pads should be wiped down with a damp cloth after every workout.
- *Periodically take the time to use a mild soap or an approved vinyl upholstery cleaner to deter the onset of cracking or drying. Avoid using any abrasive cleaners or cleaners not intended for use on vinyl.
- *Replace ripped or worn upholstery immediately.
- *Keep sharp or pointed objects clear of all upholstery.

Decals:

- *Inspect and familiarize yourself with any safety warnings or other user information posted on each decal.

Nuts and Bolts:

- *Inspect all nuts and bolts for any loosening and tighten if needed.
- *Go through a re-tightening sequence periodically to ensure that all hardware is tensioned proper.

Anti-Skid Surfaces:

- *These surfaces are designed to supply secure footing and need to be replaced if they appear worn or become slippery.

Belts and Cables:

- *Hoist uses only high quality belt, and mil-spec cables.
- *Visually inspect the belts and cables for fraying, cracking, peeling or discoloration.
- *While the machine is not in use, carefully run your fingers along the belt or cable to feel for thinning or bulging areas.
- *Replace belts and cables immediately at the first signs of damage or wear. Do not use equipment until belts or cables have been replaced.

Belt and Cable Tension:

- *Referring to the Owners Manual, when belts or cables are used check all bolts attachments to be sure they are properly attached.
- *Check slack in cables and re-adjust cable tension if needed.

Seat Sleeves, Guide Rods:

- *Wipe down adjusting tubes with a dust free rag before applying lubricant.
- *Lubricate seat sleeves and Guide Rods with a Silicon or Teflon based lubricant spray.

Linear Bearings:

- *Referring to the Owners Manual carefully disassemble the bearing from its housing and place a finger full of light grease (lithium, super lube, etc.) into the inside of the bearing. Using your finger, press the grease into the ball-bearings and their tracks. repeat until the ball-bearing tracks are full of grease. Insert the shaft back into the bearing and wipe off excess grease.

PLEASE KEEP THIS FOR YOUR RECORDS

OWNER'S MANUAL

WEIGHT TRAINING TIPS

Use this manual to guide you through the basic exercises you can perform on your V-SELECT HOIST® Fitness System. To gain maximum results and avoid possible injury, consult a fitness professional to develop your complete exercise program.

Always consult your physician before starting any exercise program.

To be successful in your exercise program, it is important to develop an understanding of the basic principles of strength training. Now that you have your V-SELECT HOIST® Fitness System, it is only natural that you want to get started immediately. First, determine a set of realistic goals and objectives for yourself. By deciding on an exercise plan that is right for you prior to starting, you will contribute significantly to your success.

Warm up properly before engaging in weight resistance training. Stretching, yoga, jogging, calisthenics or other cardiovascular exercise can help prepare your body for the heavier workload of lifting weights.

Learn how to perform the exercise correctly before using heavy weight. Correct form is important to avoid injury and to ensure that you work the proper muscle groups.

Know your limitations. If you are new to weight training or are embarking on an exercise regimen after a long layoff, start slowly and build foundational strength over a longer period of time.

Pay attention to your breathing. Exhale when you exert is a general rule of thumb. Never hold your breath.

Enjoy your V-SELECT HOIST® Fitness System!

OWNER'S MANUAL

WEIGHT RATIOS

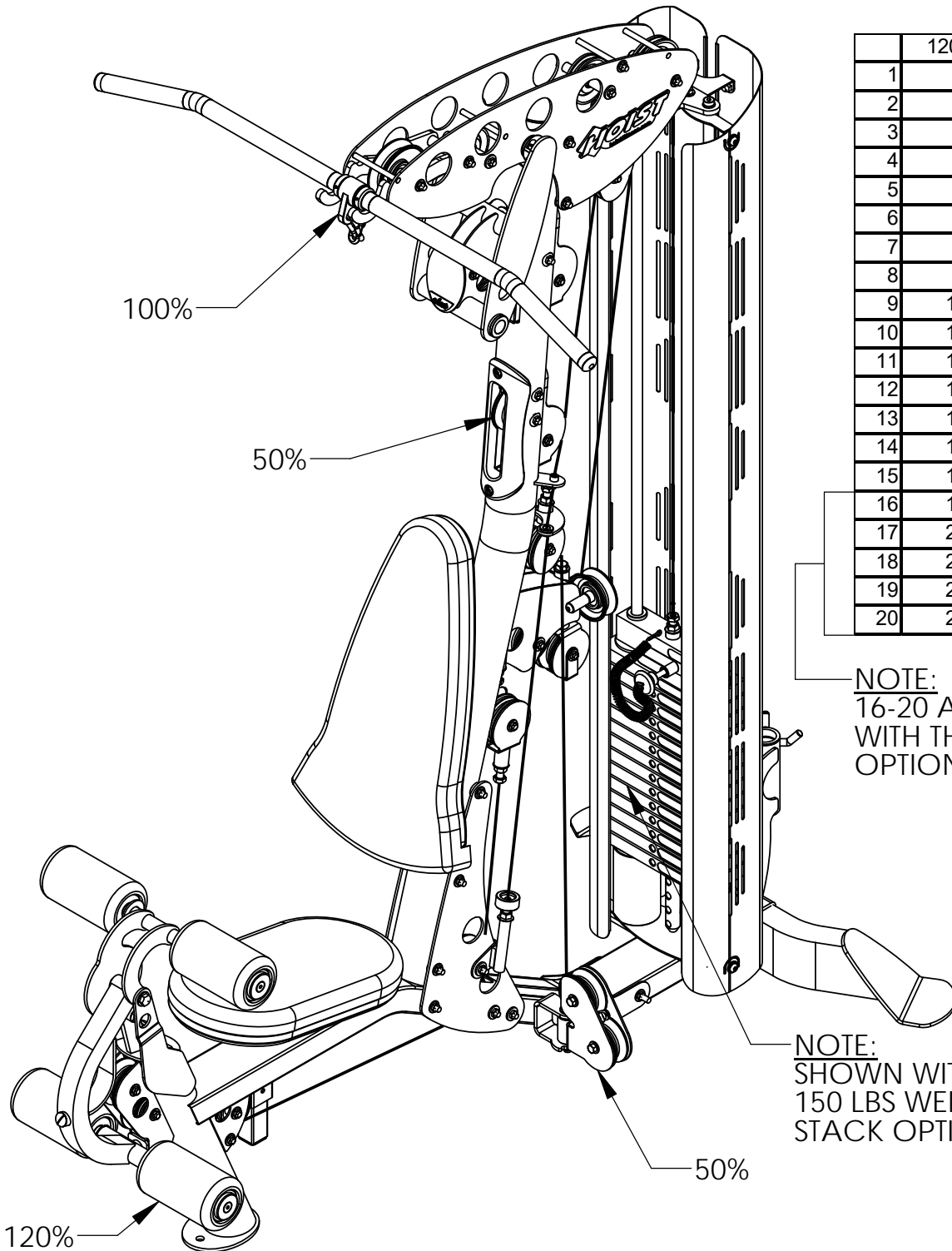

	120%	100%	50%
1	12	10	5
2	24	20	10
3	36	30	15
4	48	40	20
5	60	50	25
6	72	60	30
7	84	70	35
8	96	80	40
9	108	90	45
10	120	100	50
11	132	110	55
12	144	120	60
13	156	130	65
14	168	140	70
15	180	150	75
16	192	160	80
17	204	170	85
18	216	180	90
19	228	190	95
20	240	200	100

NOTE:
16-20 ARE USED
WITH THE 200 LBS
OPTION

NOTE:
SHOWN WITH
150 LBS WEIGHT
STACK OPTION

The above chart shows the standard weight stack for this unit. The weights listed are approximate. HOIST reserves the right to modify the machine without prior notice.

OWNER'S MANUAL

HOIST FITNESS SYSTEMS **LIMITED LIFETIME WARRANTY**

Hoist Fitness Systems warrants this product to the **original purchaser** to be free from defects in workmanship and/or materials under normal use or service. If at any time a component part is defective, Hoist Fitness Systems shall repair or replace it (at Hoist Fitness Systems option) within a reasonable period of time. This warranty does not cover costs of removal, transportation or reinstallation. This warranty shall not apply if the defect was caused by misuse, neglect or normal wear and tear.

WARRANTY CLAIMS. All claims require: Model number, Serial number, Date of installation, and any information supporting the existence of the alleged defect.

To complete Warranty Registration visit:
www.HOISTFITNESS.com
and click on the Warranty Registration link

Starting from the original date of purchase, normal wear and tear shall be considered as the following:

COMMERCIAL USE: All malfunctions of upholstery, grips, and coatings that occur up to one year; all malfunctions of belts, or **cables** up to one year; all malfunctions of pulleys, bearings, or bushings that occur up to three years. The frame and body components are warranted for ten years, with structural moving parts warranted for five years.

LIGHT COMMERCIAL USE: All malfunctions of upholstery, grips, and coatings that occur up to one year; all malfunctions of belts, or **cables** up to one year; all malfunctions of pulleys, bearings, or bushings that occur up to three years. The frame and body components are warranted for ten years, with structural moving parts warranted for five years.

HOME USE: All malfunctions of grips, paint, and chrome that occur up to ten years; all malfunctions of electronic components, belts, **cables**, or upholstery that occur up to ten years; all malfunctions of pulleys, bearings, or bushings that occur up to ten years. The frame and all welded components are warranted for the life of the product.

PLEASE NOTE THAT NOT ALL HOIST PRODUCTS ARE MADE FOR COMMERCIAL USE. Refer to the instructions page of your owners manual or consult with you fitness product dealer to establish if a product is made for commercial use or not. Using a non-commercial product in a commercial setting can result in serious injury or death! Hoist Fitness Systems sole responsibility shall be to repair or replace the component within the terms stated above. Hoist Fitness Systems shall not be liable for any loss or damage of any kind including any incidental or consequential damages resulting, directly or indirectly from any warranty expressed or implied or any other failure of this product.

LIGHT COMMERCIAL USE: Our Light Commercial warranty applies to facilities that **DO NOT** charge monthly membership dues and where the equipment would be used by **no more than 50** people per day. Examples of Light Commercial facilities include hotels, apartment complexes, personal training studios, fire stations, police stations, etc., that meet the criteria stated above.

WHAT IS NOT COVERED BY THIS WARRANTY: Hoist's sole obligation under this warranty is limited to either repair or replacement of parts, subject to the additions below. This warranty neither assumes nor authorizes any person to assume obligations other than expressly covered by this warranty.

NO CONSEQUENTIAL DAMAGES: Hoist is not responsible for economic loss; profit loss; or special, indirect, or consequential damages.

WARRANTY IS NOT TRANSFERABLE: This warranty is not assignable and applies only in favor of the original purchaser/user to whom delivered. Any such assignment or transfer shall void the warranties herein made and shall void all warranties, expressed, implied or statutory, except the one (1) and five (5) year warranties described above. These warranties are exclusive and in lieu of all other warranties, including implied warranty and merchantability or fitness for a particular purpose. There are no warranties which extend beyond the description on the face hereof.

TRANSPORTATION COSTS: Hoist will accept parts covered under this warranty freight collect, provided that shipment has received prior approval. Hoist is not responsible for any other transportation costs, but will ship freight collect parts either repaired or replaced under these warranties.

Hoist Fitness Systems
11900 Community Rd.
Poway, CA. 92064
(800)548-5438

PLEASE KEEP THIS FOR YOUR RECORDS